

Document Number	Revision	Revision Date	Product Date Code Beginning With
L4282	Rev. D	06/2023	RC models C RW models B

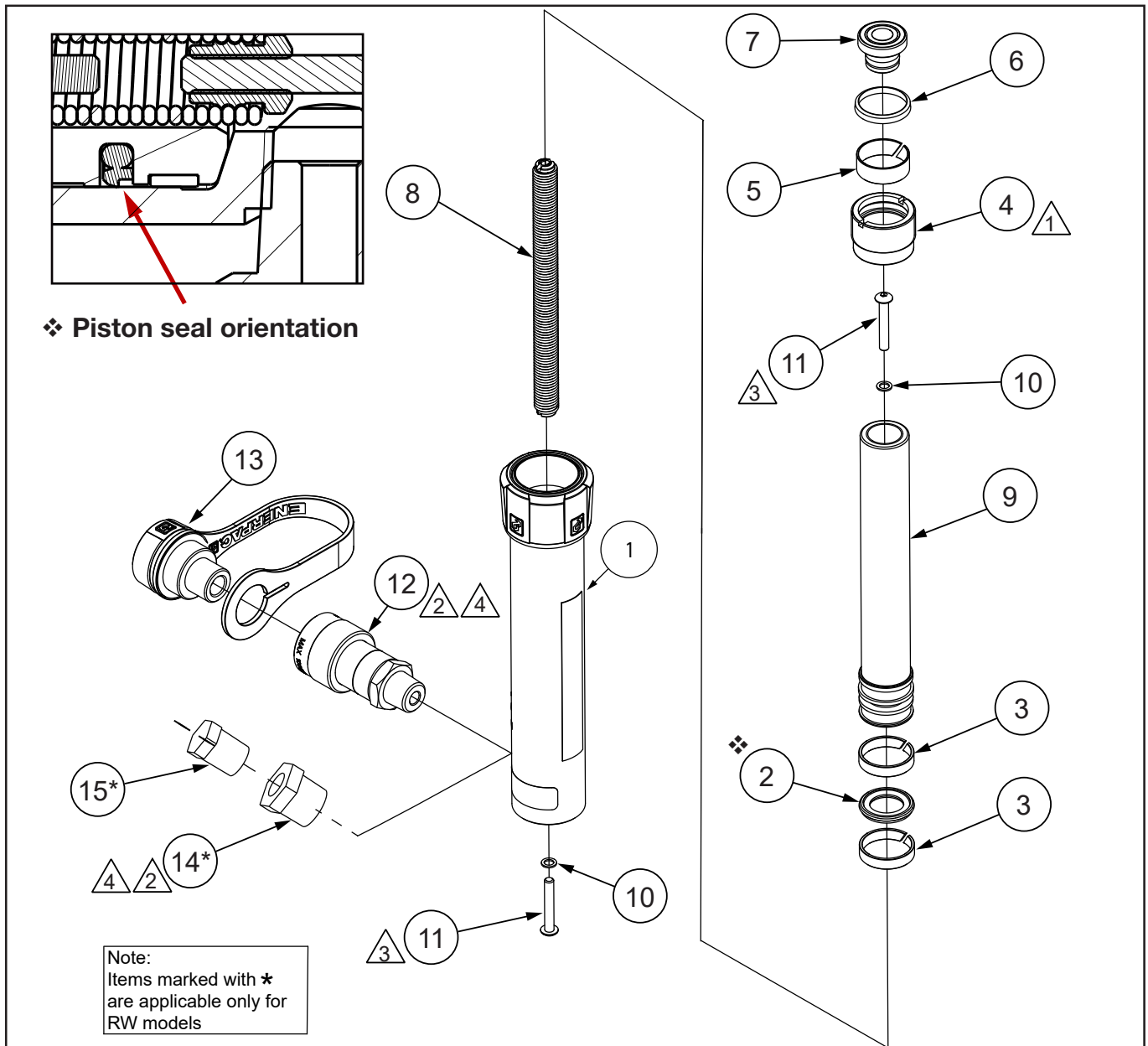

(△) Notes

Item	Torque / notes
1	Secure with threadlocker and torque to 70-90 in-lbs [7.9-10.2 Nm]
2	Torque to 40-60 ft-lbs [54-81 Nm]
3	Torque to 40-50 in-lbs [3.5-5.5 Nm]
4	Apply Loctite 545 or teflon tape

Note: See Page 2
for parts list.

Repair Parts List, Figure 1

Item	Description	Qty	RC51	RC53	RC55	RW57	RC59	RW51	RW53	RW55	
1	Base	1	N/A								
2	Piston seal	1	▲●								
3	Wear band, plunger	2*	▲★								
4	Stop ring	1	RC5044								
5	Wear band, stop ring	1	▲*								
6	Wiper	1	▲✘								
7	Saddle assembly	1	A53G								
8	Spring assembly	1	RC5K31	RC5K32	RC5K33	RC5K34	RC5K35	RC5K31	RC5K32	RC5K33	
9	Plunger	1	RC51040	RC53040	RC55040	RC57040	RC59040	RC51040	RC53040	RC55040	
10	Copper gasket	2	▲■								
11	Screw, #10-32 UNF x 1.25	2	▲■								
12	Coupler	1	CR400					N/A			
13	Dust Cap	1	CD411 ▲					N/A			
14	Reducer bushing	1	N/A					CJ657032			
15	Pipe plug	1	N/A					A8069006			
N/S	O-ring, coupler	1	▲								
N/S	Enerpac decal	1	▲								
N/S	Warning decal	1	▲								
N/S	O-ring, saddle	1	▲								
N/S	Thread protector	1	▲								

Notes:

* RC51 and RW51 only 1 plunger wear band

▲ Indicated item included in and available as a part of the Repair Kit RC5NK0

■ Indicated item included in and available as a part of the Spring Assembly

● Indicated item included in and available as packs of 10 units in Seal Kit RC5NKS (see below)

★ Indicated item included in and available as packs of 10 units in Wear Band Kit Plunger RC5NKB1 (see below)

* Indicated item included in and available as packs of 10 units in Wear Band Kit Stop Ring RC5NKB2 (see below)

✘ Indicated item included in and available as packs of 10 units in Wiper Kit RC5NKW1 (see below)

●★*✘ Kits only available in America