



For other languages go to [www.enerpac.com](http://www.enerpac.com).

Weitere Sprachen finden Sie unter [www.enerpac.com](http://www.enerpac.com).

Para otros idiomas visite [www.enerpac.com](http://www.enerpac.com).

Muunkieliset versiot ovat osoitteessa [www.enerpac.com](http://www.enerpac.com).

Pour toutes les autres langues, rendez-vous sur [www.enerpac.com](http://www.enerpac.com).

Per altre lingue visitate il sito [www.enerpac.com](http://www.enerpac.com).

その他の言語は[www.enerpac.com](http://www.enerpac.com)でご覧いただけます。

이 지침 시트의 다른 언어 버전은 [www.enerpac.com](http://www.enerpac.com).

Ga voor de overige talen naar [www.enerpac.com](http://www.enerpac.com).

For alle andre språk henviser vi til [www.enerpac.com](http://www.enerpac.com).

Inne wersje językowe można znaleźć na stronie [www.enerpac.com](http://www.enerpac.com).

Para outros idiomas consulte [www.enerpac.com](http://www.enerpac.com).

Информацию на других языках вы найдете на сайте [www.enerpac.com](http://www.enerpac.com).

För andra språk, besök [www.enerpac.com](http://www.enerpac.com).

如需其他语言，请前往 [www.enerpac.com](http://www.enerpac.com).

Note: Download the latest version of Adobe Reader at:  
<http://get.adobe.com/reader>

- W2000X • W4000X
- W8000X • W15000X

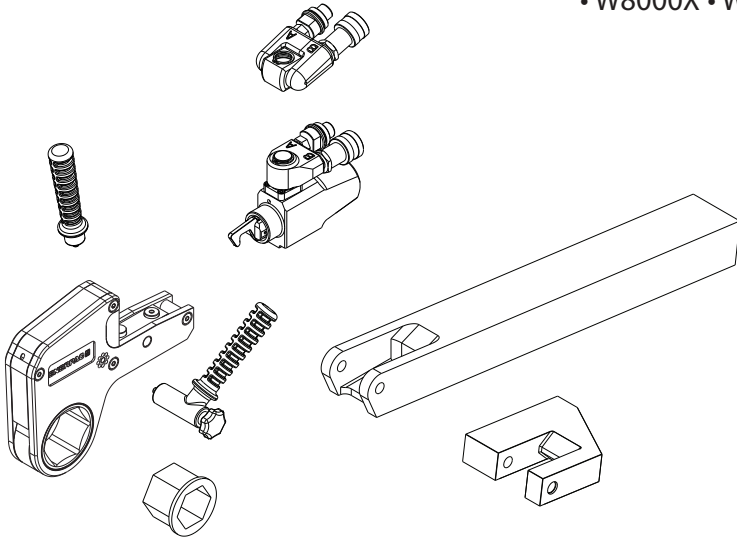

## Index

1	Introduction .....	4
2	Safety.....	4
3	Assembly and Adjustments.....	10
4	Operation.....	12
5	Maintenance and Troubleshooting.....	14
6	Technical Specifications .....	22
7	Replacement Parts and Recommended Tools.....	35

## 1 Introduction

### Overview

The Enerpac W-Series hydraulic torque wrench is designed for controlled tightening and loosening of fasteners in industrial bolting applications. The W-Series features a low profile cassette, compact drive unit and integrated reaction foot, making it ideal for use in locations where workspace is limited.

Interchangeable W-Series cassettes are available in a large assortment of both metric and imperial sizes to suit specific customer requirements.

An optional TSP300 Pro Series Swivel provides 360 degree X-axis and 160 degree Y-axis rotation, allowing easier positioning of the wrench and hoses in confined areas.

The W-Series can be used with a wide range of Enerpac bolting pumps. Electric, air and hand style pumps are available (sold separately).

### Delivery Instructions

Upon delivery all components must be inspected for damage incurred during shipping. If damage is found the carrier should be notified at once. Shipping damage is not covered by the Enerpac warranty.

### Warranty

- Enerpac guarantees the product only for the purpose for which is intended.
- All Enerpac products are guaranteed against defects in workmanship and materials for as long as you own them.

Any misuse or alteration invalidates the warranty.

- Observe all instructions as communicated in this manual.
- When replacement parts are needed, use only genuine Enerpac replacement parts.

## EU Declaration of Incorporation

W2000X • W4000X • W8000X • W15000X



These tools conform with the requirements for CE Marking.

Enerpac declares that the W-Series models listed above meet the applicable standards and directives issued by the European Union.

For additional details, refer to the separate EU Declaration of Incorporation.

## 2 Safety

Read all instructions carefully. Follow all recommended safety precautions to avoid personal injury as well as damage to the wrench and/or damage to other property. Enerpac cannot be responsible for any damage or injury from unsafe use, lack of maintenance or incorrect operation. Do not remove warning labels, tags, or decals. In the event any questions or concerns arise, contact Enerpac or a local Enerpac distributor for clarification.

If you have never been trained on high-pressure hydraulic safety, consult your distributor or service center for a free Enerpac Hydraulic Safety Course.

This manual follows a system of safety alert symbols, signal words and safety messages to warn the user of specific hazards. Failure to comply with these warnings could result in death or serious personal injury, as well as damage to the equipment or other property.





The Safety Alert Symbol appears throughout this manual. It is used to alert you to potential physical injury hazards. Pay close attention to Safety Alert Symbols and obey all safety messages that follow this symbol to avoid the possibility of death or serious personal injury.

Safety Alert Symbols are used in conjunction with certain Signal Words that call attention to safety messages or property damage messages and designate a degree or level of hazard seriousness. The Signal Words used in this manual are DANGER, WARNING, CAUTION and NOTICE.

** DANGER** Indicates a hazardous situation that, if not avoided, will result in death or serious personal injury.

** WARNING** Indicates a hazardous situation that, if not avoided, could result in death or serious personal injury.

** CAUTION** Indicates a hazardous situation that, if not avoided, could result in minor or moderate personal injury.

** NOTICE** Indicates information considered important, but not hazard related (e.g. messages relating to property damage). Please note that the Safety Alert Symbol will not be used with this signal word.

## 2.1 Safety Precautions - W-Series Hydraulic Torque Wrenches

### **WARNING**

Failure to observe and comply with the following precautions could result in death or serious personal injury. Property damage could also occur.

- Always wear protective headwear, ear protectors, footwear and gloves (at a minimum rigger type gloves) suitable for safe operation of the tool. The protective clothing must not interfere with safe operation of the tool or restrict the ability to communicate with coworkers.
- Be sure your workplace is safe. Follow the instructions in your workplace's standard operating procedures and be sure to observe all communicated safety precautions.

- Do not place any part of the body between the wrench reaction foot and the reaction point.
- Do not place any objects between the wrench reaction foot and the reaction point. Keep the hoses away from the reaction points.
- Do not stand in the line of movement of the tool when it is in operation. If the tool separates from the nut or bolt during operation it will detach in that direction.
- Be aware that a nut or bolt that breaks off during operation of the tool may become a high velocity projectile.
- Be sure appropriate guards are securely in position and free from damage.
- Keep your hands away from the fastener being loosened or tightened. Tightening and loosening nuts and bolts involves little visible movement. However, the pressures and loads are extreme.
- Stop operation immediately if a gap appears between the drive unit locating plate (on the cassette) and the drive unit housing. Have the tool inspected and repaired before it is operated again.
- Maximum allowable pressure for the W-Series torque wrench is 10,000 psi [690 bar]. Do not exceed this pressure setting.
- Always be sure that pump is stopped and all pressure is fully relieved (0 psi/ bar) before disconnecting or connecting hydraulic hoses. The sudden and uncontrolled release of pressurized oil could occur if hoses are disconnected while under pressure.
- Never attempt to connect or disconnect hoses while the pump is on and/or the system is pressurized.
- Be certain that all hose couplings are fully connected at both the pump and wrench ends before applying any

hydraulic pressure. If the couplings are not fully connected, oil flow will be blocked, and the drive unit could be subjected to excessive hydraulic pressures. Catastrophic failure of wrench could result.

- Never operate the wrench if it is known or suspected that the drive unit retaining pin is worn, bent, missing or damaged. Drive unit could disengage from the cassette and become a dangerous projectile.
- Never operate the wrench if the drive unit release handle cannot be fully closed when the drive unit is installed on the cassette. Drive unit could disengage from the cassette and become a dangerous projectile.
- Never attempt to force the drive unit onto the cassette if it becomes difficult to install. Have the drive unit and cassette inspected and repaired before placing the wrench back into service.
- Never apply more hydraulic pressure to any tool, hose, fitting or accessory than the maximum allowable pressure as stated in the manufacturer's specifications. The system operating pressure must not exceed the pressure rating of the lowest rated component in the system.
- Be sure the operator has completed safety induction training, specific to the work surroundings. The operator should be thoroughly familiar with the controls and the proper use of the tool.
- The operator must be of at least the minimum age required by applicable local regulations, laws and the facility standard operating procedures.
- Do not abuse or overstress the hoses in any way. Do not bend the hoses excessively.

- Take every precaution to prevent oil leaks from occurring. High pressure oil leaks can penetrate the skin, resulting in serious injury.
- Never strike the tool while it is pressurized or under load. Components under tension may become dislodged, allowing them to become dangerous projectiles. Uncontrolled release of pressurized hydraulic oil could also occur.
- Avoid striking the tool at any time, even when it is not pressurized or under load. Striking the tool could cause permanent damage to wrench components and may affect the wrench calibration.
- Use only a high quality nonflammable solvent for cleaning and degreasing parts during wrench repair procedures. To reduce the risk of fire or explosion, do not use flammable solvents.
- Be sure to wear proper eye and hand protection when using solvent. Always follow the solvent manufacturer's safety and use instructions and any additional instructions included in the standard operating procedures for your worksite. Be certain there is adequate ventilation when using solvent.



Failure to observe and comply with the following precautions could result in minor or moderate personal injury. Property damage could also occur.

- Always carry the wrench by its housing. Never carry the wrench using the positioning handle. The handle could break and the wrench could drop suddenly. The positioning handle is designed only as an aid to help position the wrench on the bolt or nut.

- Be sure that backup wrench (on the opposite end of nut or bolt being tightened or loosened) is secured so it cannot drop or become disengaged during bolting procedures.
- Be sure that the hex ratchet size corresponds to the size of the fastener being loosened or tightened. Failure to observe this precaution can result in the wrench becoming unstable and can lead to catastrophic failure of the tool.
- Always position the wrench for maximum stability. Use the positioning handle to properly position tool during operation.
- Be sure reaction points are adequate for the forces at work during operation of the tool.
- Be sure the reaction point is of a suitable shape. If possible, use an adjacent nut or bolt as a reaction point.
- When the hex ratchet is placed on the nut or bolt a gap may exist between the reaction foot and the reaction point. When the tool is operated the reaction foot and point will make forceful contact. Be sure the wrench is stable before applying hydraulic pressure.
- Provide adequate support in vertical and inverted applications.
- The torque required to loosen a nut is variable and may exceed the torque capacity of the wrench. Never operate the wrench at above 75 percent of its rated maximum torque when loosening a nut or bolt.
- Be sure to minimize torsional and bending stresses in the wrench, the hex ratchet and any accessories.
- Bolt lubricants and anti-seize compounds will have a rated coefficient of friction. Be sure to know the coefficient of friction for the lubricant or anti-seize compound that is being

used. To ensure proper tightening of nuts and bolts, always use this coefficient of friction when calculating required torque values.

### **NOTICE**

Failure to observe and comply with the following precautions could result in property damage and/or void the product warranty.

- Never carry the wrench by its hoses.
- Always use Enerpac pumps and hoses.
- Always use Enerpac replacement parts.
- The maximum torque output of the wrench must always exceed the torque required to loosen or tighten the nut or bolt.
- Never operate the wrench with a hydraulic supply connection to the advance side only as this may damage the internal parts.
- In severe service conditions, be aware that the wrench must be inspected, cleaned and lubricated more frequently than normal (see Section 5).
- Check that the swivel post capscrews and drive unit cylinder gland are tight prior to use. (see Section 5)
- If oil leakage is present from drive unit, replace seals as required (see section 5) before placing the drive unit back into service.
- If the wrench is dropped from a significant height, have the tool inspected and checked for proper operation before placing it back into service.
- Always follow the inspection and maintenance instructions contained in this manual. Perform maintenance and inspection activities at the specified time intervals.

## Use of Torque Wrenches in Explosive Atmospheres

In addition to the CE mark, the Enerpac W-Series torque wrenches carry the ATEX mark and classification:

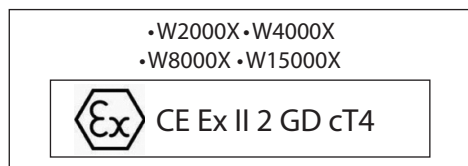

This classification indicates that the tool is appropriate for use in a potentially explosive atmosphere.

The testing standards applicable to the W-Series torque wrenches are the standard EN 13463-1:2009, Non-electrical equipment for use in potentially explosive atmospheres. Part 1: Basic method and requirements, and also the draft standard of ISO/IEC 80079-36.

Contact Enerpac if there are any questions regarding the ATEX classification or questions regarding application of the W-Series torque wrenches in hazardous environments.

### Reducing the Risk of Explosion



Failure to observe and comply with the following precautions and instructions could result in explosion and/or fire. Death and/or serious personal injury could occur.

- To help reduce the risk of explosion, be certain to use the W-Series torque wrench only in the specific explosive atmospheres for which it has been tested and certified. Refer to the beginning of this section for ATEX classification information.

- The W-Series torque wrench is generally not considered as a potential source of ignition. However, proper operation and maintenance of the tool is essential in order to help ensure that no sparks are generated that could cause an ignition of an explosive gas or dust mixture (which might be present in the environment). Complete operation and maintenance instructions must be provided to all personnel in advance of operating or servicing the wrench.
- Hot surfaces can be a major source of ignition. To help prevent the possibility of ignition resulting from excessive surface temperatures, do not use the wrench in an environment with an ambient temperature of above 104°F [40°C].
- Enerpac has designed and constructed the W-Series torque wrench to minimize the possibility of an incendive spark that may be caused by the impact of aluminum components with corroded steel. However, to reduce the chance of an incendive spark, use of the wrench with corroded steel structures or components should be avoided whenever possible. Be especially careful to avoid accidental impacts with the wrench and corroded steel.

**NOTICE** To help prevent a mechanical spark hazard, no components containing a magnesium content greater than 7.5 percent have been used in the W-Series torque wrench (in accordance with standard EN 13463-1).

- 
- Take extreme care to prevent the W-Series torque wrench from being dropped on the floor or onto any other metallic surface that might cause mechanical sparks at impact. Also, take every precaution to prevent other tools (or other metallic objects) from dropping onto the W-Series torque wrench.

#### Electrostatic Discharge

- Electrostatic discharge is a potential source of ignition and can result in electrostatic build-up on isolated conductive parts. Isolated conductive parts create capacitive poles which can become charged. Electrostatic discharge risk is minimized by the hydraulic hoses, which have multiple layers of steel braiding, resulting in electrical continuity between the torque wrench and the grounded hydraulic pump.
- Non-conductive polyester labels could be a site for electrostatic build-up. However, electrostatic build-up is prevented by the close proximity of the grounded torque wrench body.

## 3 Assembly and Adjustments

### 3.1 Overview and features (Fig. 1 or 2)

- 1 Hexagon ratchet
- 2 Cassette
- 3A Hydraulic Swivel (standard)
- 3B TSP300 Pro Series Swivel (optional)
- 4 Advance hose connection
- 5 Return hose connection
- 6 Hydraulic drive unit
- 7 Cassette release lever
- 8 Reaction foot

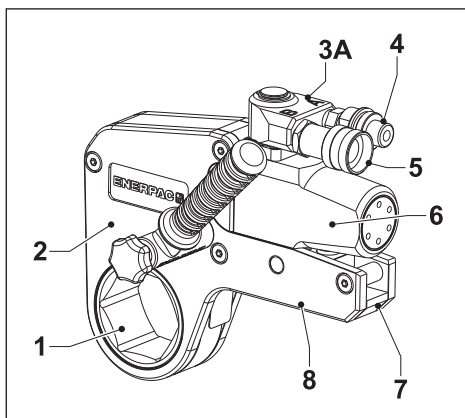

Fig. 1

### 3.2 To attach the positioning handle (Fig. 3)

- Secure the positioning handle (9) with thumb screw (10). Positioning handle can be installed on either side of wrench.

### 3.3 Changing the Cassette

**⚠ WARNING** Be sure that hydraulic pump is OFF and that hydraulic system is depressurized (0 psi/bar) before removing or attaching the cassette. Drive unit could eject under force if this precaution is not followed, resulting in possible personal injury.

#### 3.3.1 To Remove the Cassette

(Fig. 4 and 5)

- Be sure the drive unit piston is fully retracted.
- Firmly grasp the cassette housing with your hand or place the tool on a workbench.

**NOTICE** Cassette will disengage from drive unit in the following steps. Be sure to support the cassette so that it does not drop.

- Pull the cassette release lever (7) outwards.
- Remove the hydraulic drive unit (6) from the cassette (2).

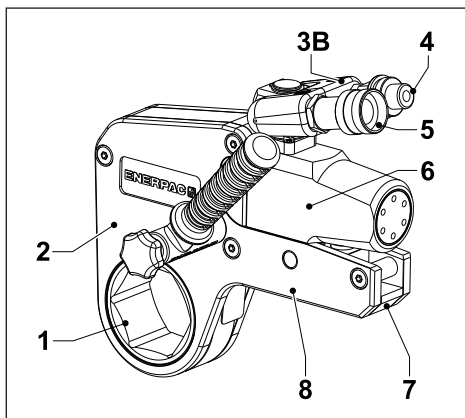

Fig. 2

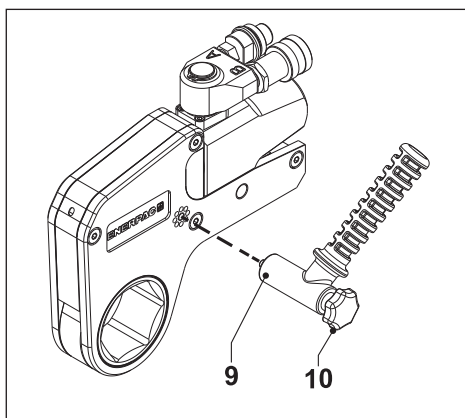

Fig. 3

### 3.3.2 To Attach the Cassette (Fig. 4 and 5)

- Pull the release lever (7) outwards.
- Be sure the retract link (11) aligns with the slot (13) in the ratchet lever. Rotate the piston rod if necessary.
- Slide the drive unit onto the cassette and push the spigot (12) through the opening in the drive unit locating plate (14).
- Push the release lever (7) back into the cassette (2). Be sure the ball detent clicks into place. Check that cassette release lever is fully closed.

**CAUTION** Do not operate the tool if the cassette release lever is not fully closed. Drive unit could be ejected with great force if lever is not fully closed, Personal injury and/or damage to tool could result.

### 3.4 To Connect Accessories

#### 3.4.1 To Attach the WTE Series Extended Reaction Arm (Fig. 6)

- Remove the spacer retaining pin engraved \*000110A (where \* equals wrench series i.e. 2, 4 etc.) from the cassette.
- Install the cassette in to the cut out in the WTE Series extended reaction arm (19) aligning the holes in the arm with the hole in the cassette.
- Install the long pin engraved \*000134 (where \* equals wrench series i.e. 2, 4 etc.) supplied with the WTE Series extended reaction arm through the arm and cassette
- Ensure that the pin is fully engaged with the arm on both sides.

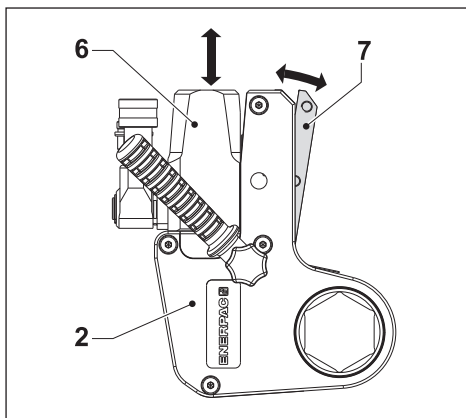

Fig. 4

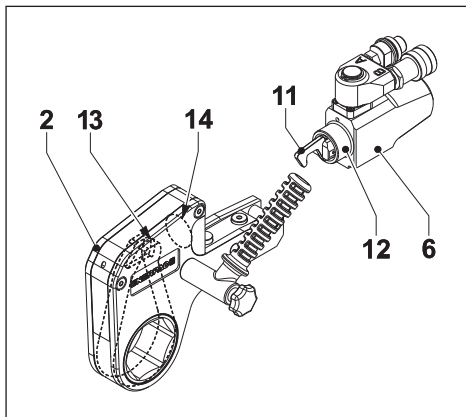

Fig. 5

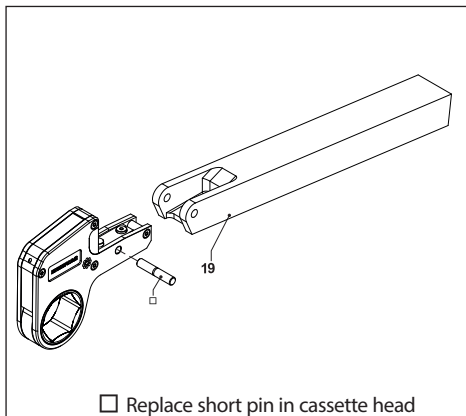

Fig. 6

### 3.4.1 To Attach the WRP Series Reaction Paddle (Fig. 7)

- Remove the spacer retaining pin engraved \*000110A (where \* equals wrench series i.e. 2, 4 etc.) from the cassette.
- Install the cassette in to the cut out in the WRP Series reaction paddle (20) aligning the holes in the paddle with the hole in the cassette.
- Install the long pin engraved \*000137 (where \* equals wrench series i.e. 2, 4 etc.) supplied with the WRP Series reaction paddle through the paddle and cassette.
- Ensure that the pin is fully home, the top hat of the pin should be located in the paddle counterbore.

### 3.5 To Connect the Hoses (Fig. 8)

**⚠ WARNING** Be sure all hoses and fittings are rated for at least 10,000 psi [690 bar] operation. Check that all hydraulic couplings are securely connected before operating the tool. Failure to observe these precautions may result in the hoses bursting or disconnecting under pressure. High pressure oil leakage may also occur. Serious personal injury could result.

The tool is fitted with male and female 1/4 inch NPTF spin-on hydraulic couplings. Use Enerpac twin safety hoses only. Refer to the table below.

Enerpac hose model number	Description
THQ-706T	Two hoses, 19.5 feet [6 m] long
THQ-712T	Two hoses, 39 feet [12 m] long

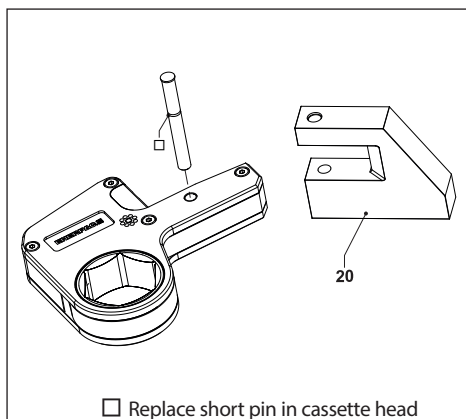

Fig. 7

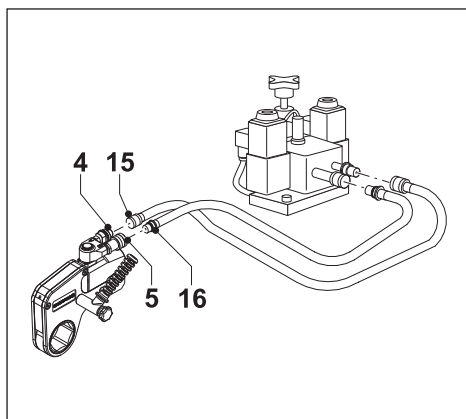

Fig. 8

Connect hoses to wrench as described in the following steps:

- Be sure that all pressure in system is relieved and that pressure gauge indicates zero (0) psi/bar.
- Remove the hose dust caps.
- Connect the hose with the female coupling (15) to the wrench advance coupling (4).
- Connect the hose with the male coupling (16) to the wrench return coupling (5).
- At each connection, pull the collar on the female coupling over the male coupling.

Engage threads and hand tighten the collar.

- Connect the hoses to the pump.  
Refer to the pump instruction manual.

## 4 Operation

### 4.1 Prior to Operation

- Be sure the nut or bolt to be fastened is clean and free of loose dust or dirt.
- Be sure the nut threads properly engage with the threads of the bolt, and that cross-threading has not occurred.
- Be sure that the threads and the bearing surface are liberally coated with the correct bolt lubricant or anti-seize compound.
- Make all torque calculations based on the bolt lubricant's (or anti-seize compound's) stated coefficient of friction. Failure to do so may result in the required bolt load not being achieved.
- Be sure that the backup wrench (used to keep the nut or bolt on the opposite end in place) is correctly positioned and secured.

**⚠ WARNING** Be certain that backup wrench is of the correct size and that there is an adequate abutment surface. Personal injury could occur if backup wrench loosens or dislodges during bolting procedures.

- Contact Enerpac for additional guidance if a suitable reaction point is not available.

### 4.2 Setting the Torque

Adjust the pressure on the pump as necessary to set the torque. Refer to pump manufacturer's instruction manual.

## 4.3 Wrench Operation

### **⚠ WARNING**

Failure to observe the following precautions could result in serious personal injury:

- Stop operation immediately if a gap appears between the drive unit locating plate and the drive unit. A gap in this location indicates that the drive unit retaining pin is worn or damaged, and must be repaired. Use of wrench with worn or damaged retaining pin may result in the drive unit forcefully ejecting from the cassette.
- Never strike the tool with a hammer or other object while it is under load. Catastrophic failure of the wrench could occur, and dislodged parts could become dangerous projectiles. Uncontrolled release of hydraulic oil could also occur. Refer to Section 2 of this manual for additional information.

### 4.3.1 Tightening a Nut or Bolt (Fig. 9 and 10)

- Position the tool on the nut or bolt with the clockwise (+) side facing upwards.
- Position the reaction foot (17) against a suitable reaction point (18). The reaction point will counteract the force caused by operating the tool.
- Start the pump.
- Operate the pump until the nut or bolt has been tightened to the required torque.
- Stop the pump immediately after work has finished.

### 4.3.2 Nut and Bolt Loosening Information

- Be aware that more torque is usually required to loosen a fastener than to tighten it.

- Rusted fasteners (humidity corrosion) may require up to twice the torque required for tightening.
- Fasteners that are corroded due to contact with sea water or chemicals will require up to two and a half times the torque required for tightening.
- Heat corrosion requires up to three times the torque required for tightening.

**⚠ WARNING** Do not apply more than 75 percent of the wrench's maximum torque when loosening nuts or bolts. Avoid making sudden start-stop movements ("shock loading"). Failure to observe these precautions may cause a catastrophic failure of the wrench to occur, and wrench components under high tension could become dangerous projectiles. Serious personal injury could result.

#### 4.3.3 Loosening a Nut or Bolt (Fig. 11 and 12)

- Apply penetrating oil to the threads. Allow the oil to soak.
- Position the tool on the nut or bolt with the anti-clockwise (-) side facing upwards.
- Position the reaction foot (17) against a suitable reaction point (18). The reaction point will counteract the force caused by operating the tool.
- Start the pump.
- Operate pump until nut (bolt) is loose. If the nut or bolt will be re-used, avoid excess load when loosening.

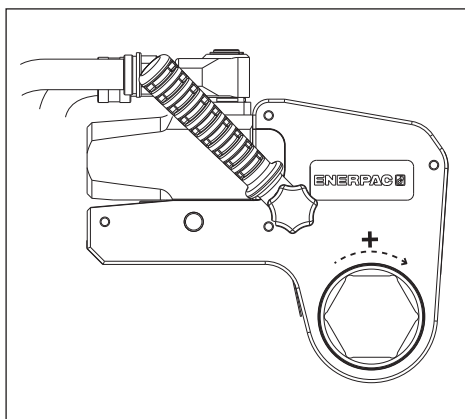

Fig. 9

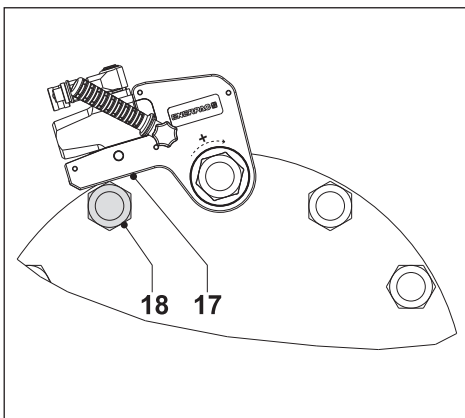

Fig. 10

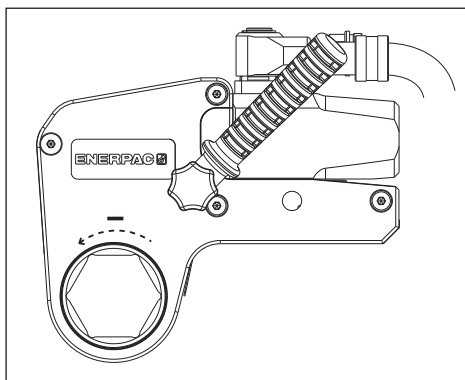

Fig. 11

**⚠ WARNING** During loosening, a nut or bolt may be subjected to stresses beyond its material limits, which could result in a permanent reduction of its strength. This reduction could lead to catastrophic failure of the nut, bolt or joint if the fastener is reinstalled. If there is any doubt as to whether the force used during loosening has caused excessive stress, the removed fastener(s) should be discarded and replaced with new fastening of the proper specifications.

#### 4.3.4 Using an Extended Reaction Arm (Fig. 13)

- Position the WTE Series extended reaction arm (19) against a suitable reaction point. The reaction point will counteract the force caused by operating the tool.
- Follow instructions in sections 4.3.1 through 4.3.3.

#### 4.3.5 Using a Reaction Paddle (Fig. 14)

- Position the WRP Series reaction paddle (20) against a suitable reaction point. The reaction point will counteract the force caused by operating the tool.
- Follow instructions in sections 4.3.1 through 4.3.3.

## 5 Maintenance and Troubleshooting

### 5.1 Introduction

Preventative maintenance can be performed by the user.

Full maintenance must be performed only by an Enerpac authorized service center or a qualified and experienced technician.

Recommended service intervals are:

- 3 months – Heavy Duty use
- 6 months – Normal use
- 12 months – Infrequent use

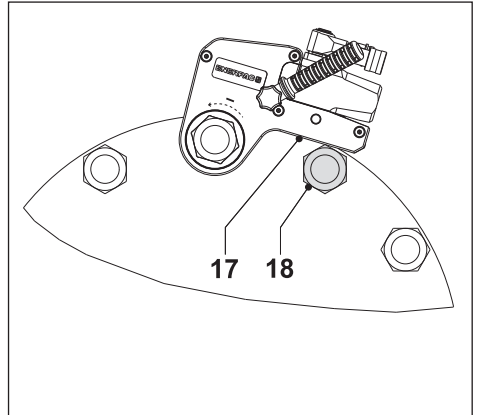

Fig. 12

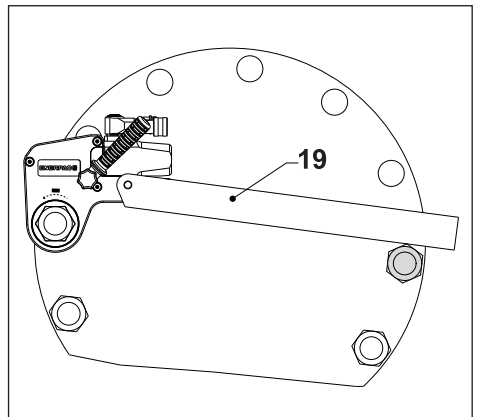

Fig. 13

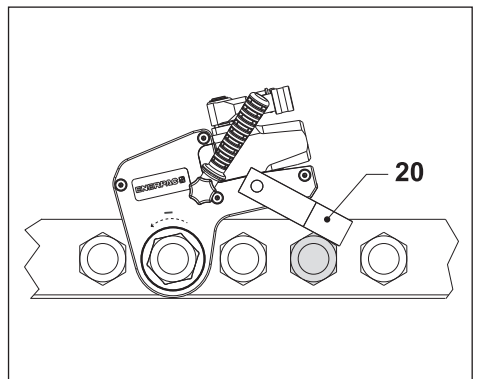

Fig. 14

Non destructive testing must be carried out if the tool has been used under severe conditions.

### 5.2 Preventative Maintenance - Hydraulic Swivel and Drive Unit (Fig. 15 and 16)

- Check tightness of swivel post capscrews and gland (see 5.3).
- Pressurize the drive unit to maximum pressure (advance and retract), and check for any signs of leakage.
- Any damaged components or seals must be replaced.
- Dry all components and apply a thin coat of molybdenum disulphide grease as indicated (♣).

### 5.3 Full Maintenance - Hydraulic Swivel and Drive Unit (Fig. 16, 17 and 19)

Disassembly:

- Remove the circlip (A).
- Using a pair of flat blade screwdrivers, gently pry the swivel assembly (B) from the swivel post (F).
- Remove O-rings (C) from the grooves inside the swivel assembly (B).

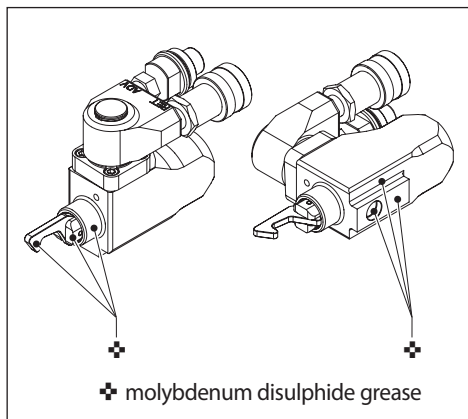

Fig. 15

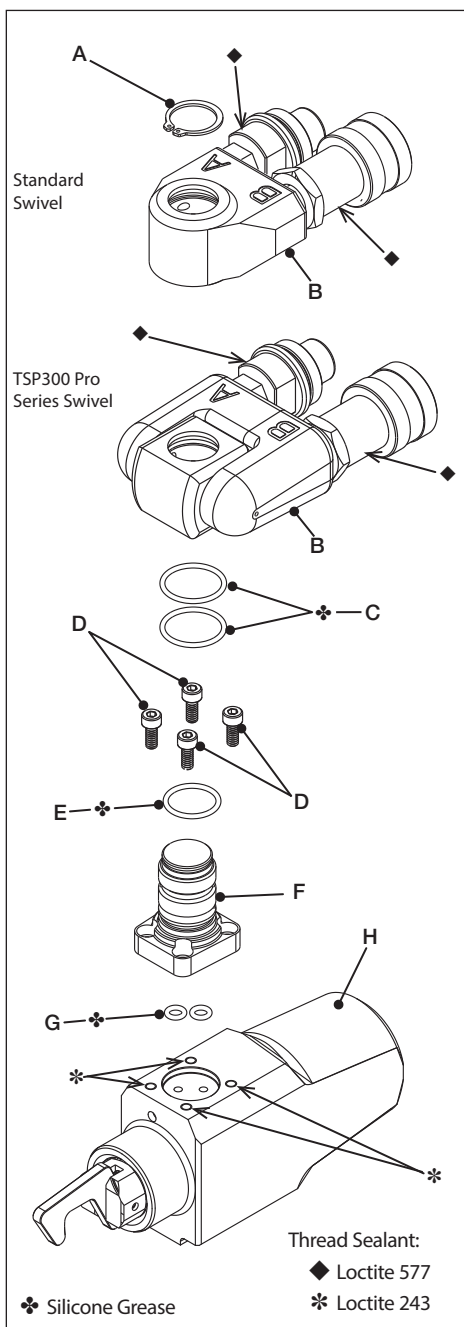

Fig. 16

- Place the swivel assembly in a vise with soft jaws. Remove the hydraulic couplings (B1, B2 and B3) from the swivel assembly (B).

**NOTICE** For drive units equipped with the optional TSP300 Pro Series swivel, refer to Enerpac instruction sheet L4119 for additional disassembly instructions.

- Remove the socket head capscrews (D) and the swivel post (F). Remove O-rings (G) from the swivel post hydraulic ports.
- Remove O-ring (E) from the swivel post (F).
- Firmly hold the drive unit housing (H2). Using an appropriate pin spanner, unscrew and remove the cylinder gland (H9). Remove O-ring (H8) from the gland.
- At the Spigot End of the drive unit, hold the two flat sides of the piston rod (H1) with a spanner wrench.
- Remove the piston retaining screw (H7) from the piston (H6).
- Remove the piston rod (H1) from the Spigot End of the drive unit housing (H2).
- Using a suitable drift, remove the piston (H6) from the Gland End of the drive unit housing (H2).
- Remove O-ring (H4) from the groove on inside of piston (H6).
- Remove seal (H5) from the groove on outside of piston (H6).
- Remove seal (H3) from groove inside drive unit housing (H2).
- Clean all exposed components with a mild solvent.
- Inspect all parts for damage.
- Perform magnetic particle inspection on the following components:
  - Drive unit housing (H2)
  - Piston rod (H1)

Reassembly:

**NOTICE** In the following steps, coat all O-rings and seals with silicone grease before installation.

- Install seal (H5) in groove on outside of piston (H6).
- Install seal (H3) in groove inside drive unit housing (H2). Be sure that "V" side of seal is facing toward the Gland End of housing (H2).

**NOTICE** During reassembly in the following steps, be sure that the piston rod (H1) is inserted through the Spigot End of the housing (H2).

**NOTICE** Do not use excessive force when installing the piston. This may damage the piston and sealing faces within the drive unit.

- Coat the piston rod (H1) with silicone grease and carefully slide it through the Spigot End opening of the housing (H2).
- Assemble the piston (H6) on the end of the piston rod (H1). Gently tap the piston (H6) into place against the piston rod (H1).

**WARNING** Be certain that piston retaining screw (H7) is securely tightened in the following step. If screw is not tight, piston rod (H1) could be ejected from drive unit when hydraulic power is applied. Serious personal injury could result.

- Apply Loctite 243 thread sealant to the threads of the piston retaining screw (H7) before installation. Tighten piston retaining screw securely.
- Install O-ring (H8) in groove on gland (H9).
- Screw the gland (H9) into the drive unit housing (H2) by hand, making sure that the O-ring (H8) is not pinched or cut.
- Using an appropriate pin spanner, fully tighten the gland (H9). Tap the pin spanner with a suitable mallet to ensure that gland (H9) is tightly installed.

Refer to Figs. 14 and 17 for swivel components.

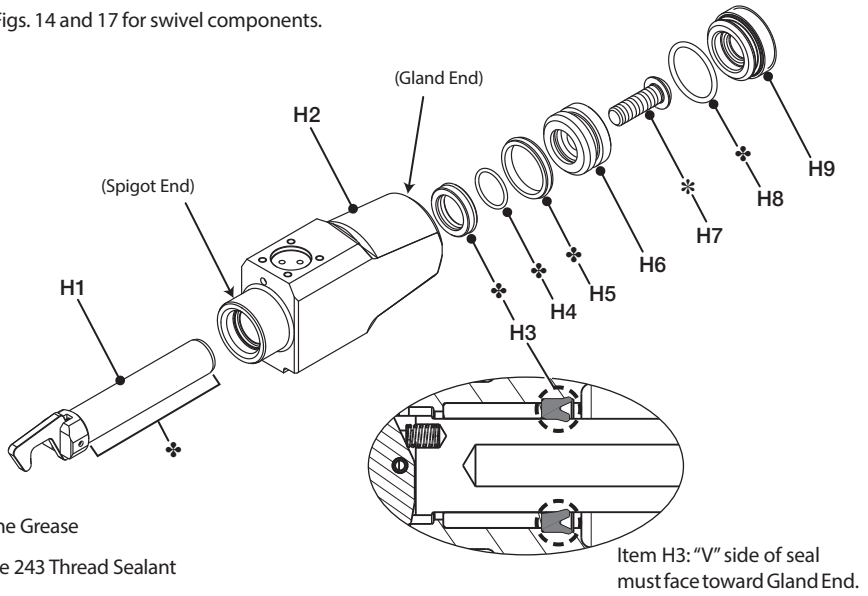

Fig. 17

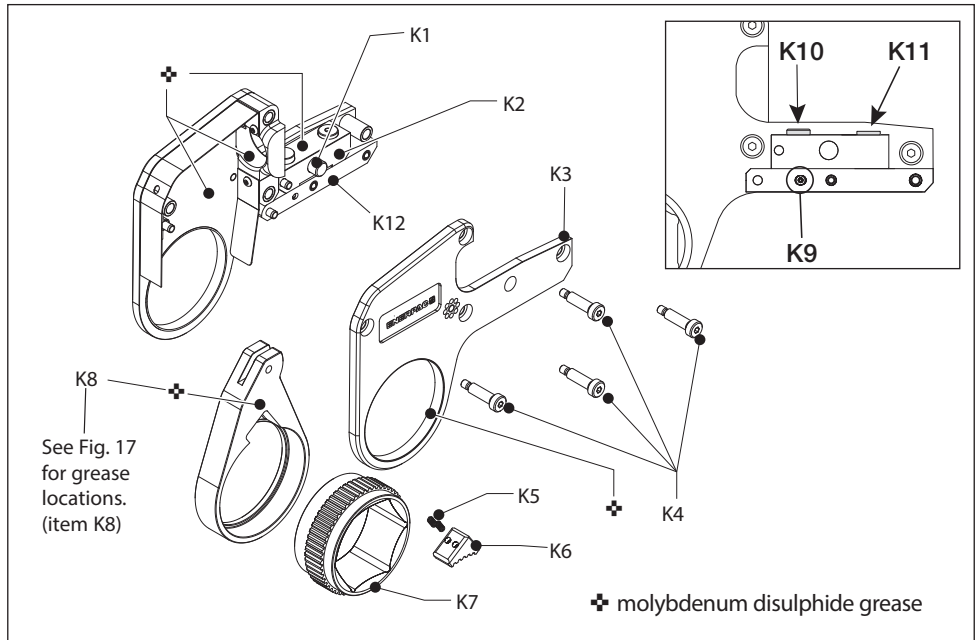

Fig. 18

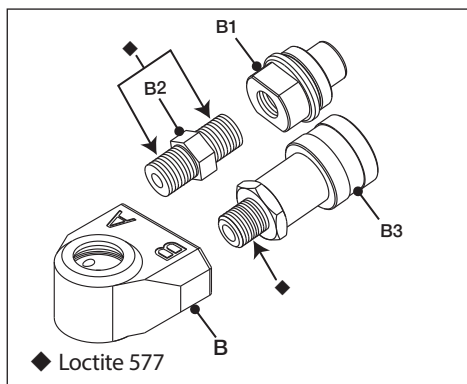

Fig. 19

- Apply a small amount of Loctite 243 thread sealant to the threaded holes in the drive unit. See (\*) in Figure 16 for locations.
- Install two O-rings (G) into the ports on the base of the swivel post (F).
- Place the swivel post (F) on the drive unit (H), making sure that hydraulic ports are aligned. Be careful that O-rings (G) do not drop out or become pinched or cut.
- Install the degreased socket head capscrews (D) and tighten them as follows:
  - a) W2000X and W4000X:  
(M4 capscrews) – 3.7 Ft.lbs [5.1 Nm]
  - b) W8000X and W15000X:  
(M5 capscrews) – 7.5 Ft.lbs [10.2 Nm]
- If the drive unit is equipped with the optional TSP300 Pro Series swivel, refer to Enerpac instruction sheet L4119 for additional reassembly instructions.

**NOTICE** Install the couplings (B1 and B3) and adapter (B2) before installing the swivel (B) on the swivel post (F). Use a vise with soft jaws to hold the swivel as couplings and adapter are installed.

- Apply Loctite 577 sealant to threads on female coupling (B3) and adapter (B2). See (◆) in Figure 19 for locations.
- Tighten the couplings (B1 and B3) and adapter (B2) by hand, until they are each finger tight. Then, wrench tighten these parts an additional 2 to 3 turns beyond finger tight.

**NOTICE** To allow the sealant sufficient time to cure, wait a minimum period of 3 hours at 68 to 104°F [20 to 40°C], or 6 hours at 40 to 68°F [5 to 20°C] before pressurizing the drive unit.

- Install a O-ring (E) into the groove on the swivel post (F).
- Install O-rings (C) into the grooves inside the swivel assembly (B).
- Coat O-rings (E and C) with a small amount of silicone grease. Then, carefully slide the swivel assembly (B) onto the swivel post (F).
- Reinstall the circlip retainer ring (A).
- Connect hydraulic hoses and cycle the drive unit at 1,000 psi [69 bar] to check for oil leaks. If there are no leaks, cycle the drive unit at 10,000 psi [690 bar] and check again for leaks.

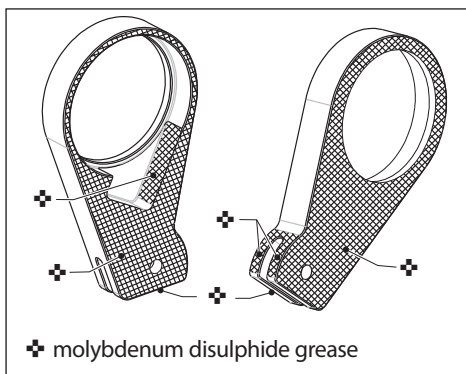

Fig. 18

**⚠ WARNING** Pressurized hydraulic oil can penetrate the skin and could cause serious personal injury. Always repair any oil leaks before using the wrench.

#### 5.4 Preventative Maintenance - Cassette (Fig. 18 and 20)

- Remove the cassette from the drive unit.
- Remove the screws (K4). Lift and remove the sideplate (K3).
- Remove the ratchet lever (K8), hex ratchet (K7), spring loaded drive shoe (K6), and compression spring(s) (K5).

The W2000X Series cassettes use one compression spring. The W4000X, W8000X and W15000X Series cassettes use two compression springs.

- Clean all exposed components with a mild solvent.
- Inspect all parts for damage.
- Dry all components. Apply a thin coat of molybdenum disulphide grease as indicated (⚡).

**NOTICE** When lubricating the ratchet lever (K8), apply molybdenum disulphide grease (⚡) only to the shaded areas shown in Fig. 20.

NEVER apply molybdenum disulphide grease (⚡) to the ratchet lever bore, or to the drive shoe teeth. Application of grease to these areas will cause erratic operation, slippage of drive mechanism and excessive component wear.

- Reverse the disassembly procedure to reassemble the tool.

#### 5.5 Full Maintenance - Cassette (Fig. 18, 20 and 21)

- Strip down and clean all exposed components with a mild solvent.
- Drift out the roll pin (K9) holding the drive unit retaining pin (K10) in place. Remove and inspect drive unit retaining pin (K10). Replace if worn or damaged.

- Inspect all other parts for damage.
- Perform magnetic particle inspection on the following components:
  - Spacer Retaining Pin (K1)
  - Pin Retainer (K2)
  - Sideplates (K3)
  - Drive Shoe (K6)
  - Ratchet (K7)
  - Ratchet Lever (K8)
  - Drive Unit Retaining Pin (K10)
  - Fail Safe Retaining Pin (K11)
  - Release Lever/Reaction Foot (K12)
- Reinstall drive unit retaining pin (K10) and roll pin (K9).

**⚠ WARNING** Always reinstall drive unit retaining pin (K10) if removed. Do not operate wrench if retaining pin (K10) is not installed. Failure to reinstall retaining pin (K10) may allow the drive unit to be ejected from the cassette during operation, resulting in possible personal injury.

- Check for the correct height for the drive unit retaining pin (K10) and the fail safe retaining pin (K11). See Figure 21, dimensions "X" and "Y".
- Dry all components. Apply a thin coat of molybdenum disulphide grease (⚡) as indicated in Figures 18 and 20. Refer to Section 5.4 for additional information about application of molybdenum disulphide grease.
- Reverse the disassembly procedure to reassemble the tool.

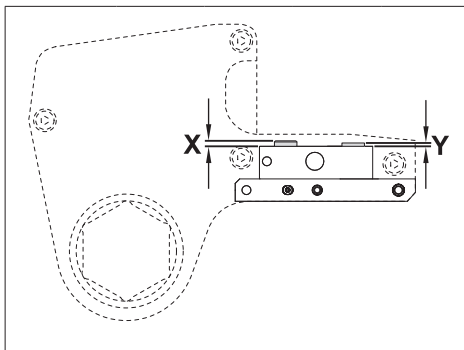

Fig. 21

Model	Drive Unit Retaining Pin Dimension X		Fail Safe Retaining Pin Dimension Y	
	(inch)	(mm)	(inch)	(mm)
W2000X	0.157	4.00	0.118	3.00
W4000X	0.197	5.00	0.118	3.00
W8000X	0.236	6.00	0.157	4.00
W15000X	0.275	7.00	0.236	6.00

## 5.6 Troubleshooting

### 5.6.1 Drive Unit

Symptom	Cause	Remedy
Drive unit piston does not advance or retract.	Hydraulic coupling is damaged.	Replace the coupling.
	Hydraulic coupling is not connected.	Be sure that advance and retract hoses are connected at both pump and wrench. Check that all hose couplings are fully installed.
	Worn or damaged directional control valve on the hydraulic pump.	Take pump to authorized service center. Make repairs as required.
Drive unit does not build up pressure.	Piston seal leaks.	Replace the seals.
	Pump does not build pressure.	Adjust the pressure.
	Pump is defective.	Refer to the pump manual.
Drive unit leaks.	Seal failure.	Replace the drive unit seals.
Drive unit piston operates backwards.	Hose connections are reversed.	Reconnect the hoses properly.
Gap between drive unit housing and locating plate on cassette.	Drive unit retaining pin is worn, damaged or missing.	Replace the drive unit retaining pin.

### 5.6.2 Cassette

Symptom	Cause	Remedy
Ratchet returns on retract stroke.	Broken drive shoe.	Replace the drive shoe.
Ratchet does not take successive strokes.	Broken ratchet lever or ratchet.	Replace ratchet lever and/or ratchet (as required).
	Worn or broken drive shoe.	Replace the drive shoe.
	Lubricant on the ratchet and/or drive shoe splines.	Disassemble the cassette and remove the lubricant from splines.

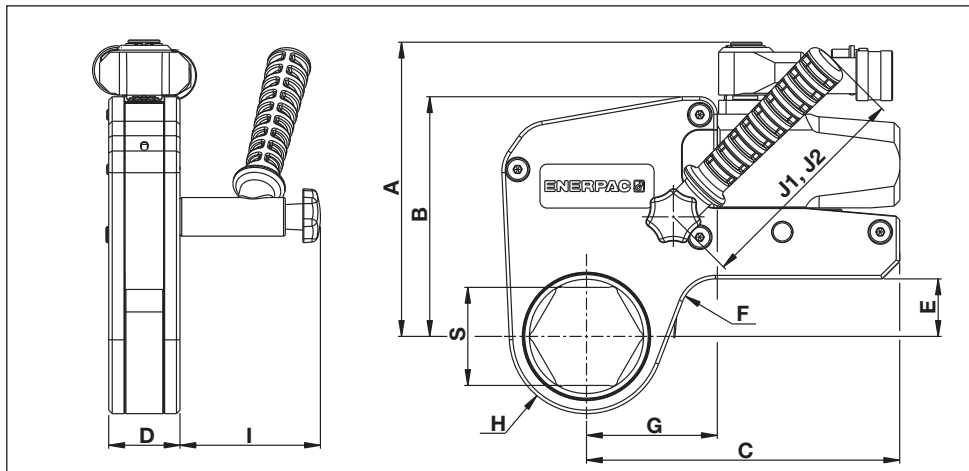

Fig. 22

## 6 Technical specifications

### 6.1 Capacities, Dimensions and Additional Product Data (Fig. 22)

		W2000X	W4000X	W8000X	W15000X	
Hexagon size range of available cassettes	inch	1 1/16 - 2 3/8	1 5/16 - 3 3/8	1 7/8 - 4 1/8	2 7/16 - 4 5/8	
	mm	30 - 60	36 - 85	50 - 105	65 - 115	
Maximum operating pressure	psi	10,000	10,000	10,000	10,000	
	bar	690	690	690	690	
Nominal torque at 10,000 psi	Ft.lbs	2,040	4,175	8,470	15,330	
	Nm	2,766	5,661	11,484	20,785	
Min. torque at 690 bar	Ft.lbs	204	418	847	1,533	
	Nm	277	566	1,148	2,079	
Weight, Drive Unit	lbs	2.9	4.2	6.8	11.0	
	kg	1.3	1.9	3.1	5.0	
Weight, Cassette		(See Sections 6.2.1 through 6.2.6)				
Dimensions	A	inch [mm]	4.29 [109.0]	5.35 [136.0]	6.77 [172.0]	8.15 [207.0]
	B	inch [mm]	5.55 [141.0]	6.57 [167.0]	8.07 [205.0]	9.45 [240.0]
	C	inch [mm]	5.83 [148.0]	7.01 [178.0]	8.19 [208.0]	9.96 [253.0]
	D	inch [mm]	1.26 [32.0]	1.61 [41.0]	2.07 [52.5]	2.48 [63.0]
	E	inch [mm]	0.94 [24.0]	1.29 [32.8]	1.65 [41.9]	1.97 [50.0]
	F	inch [mm]	0.79 [20.0]	0.79 [20.0]	0.98 [25.0]	0.79 [20.0]
G, H, S		(See Sections 6.2.1 through 6.2.6)				
I, J1, J2		(See Sections 6.1.3 and 6.1.4)				

**NOTICE** If wall thickness of hexagon reducer insert is less than shown in the table at right, the insert's usable life may be significantly reduced.

Minimum Wall Thickness - Hexagon Reducer Insert	
W2000X Series	..... 0.14 inch [3.50 mm]
W4000X Series	..... 0.18 inch [4.69 mm]
W8000X Series	..... 0.24 inch [6.0 mm]
W15000X Series	..... 0.26 inch [6.69 mm]

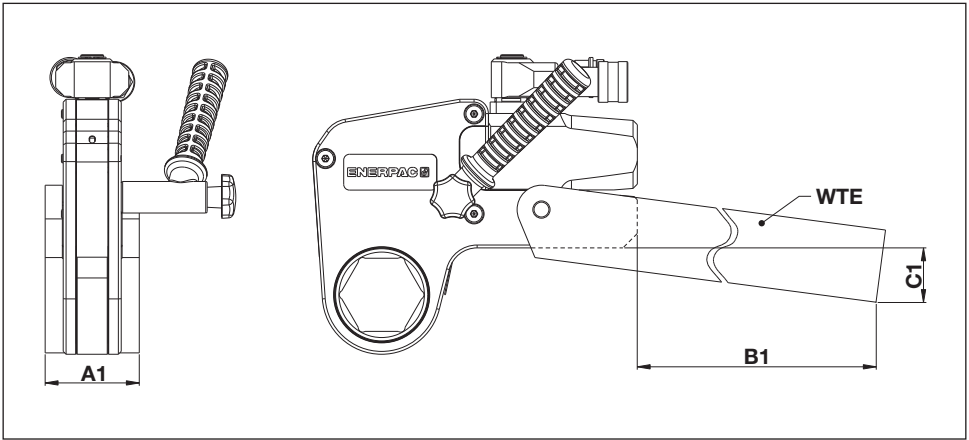

Fig. 23

6.1.1 Dimensions, WTE Series Extended Reaction Arm (Fig. 23)

Wrench Series			W2000X	W4000X	W8000X	W15000X
Reaction Arm Model			WTE20	WTE40	WTE80	WTE150
Dimensions	A1	inch [mm]	2.20 [56]	2.59 [66]	3.35 [85]	4.05 [102]
	B1	inch [mm]	15.67 [398]	17.17 [436]	17.68 [449]	19.60 [498]
	C1	inch [mm]	2.66 [67.5]	2.90 [74]	2.15 [54.5]	2.80 [72]
Weight		lbs [kg]	5.73 [2.6]	10.14 [4.6]	16.75 [7.6]	26.46 [12.0]

(Reaction arm only)

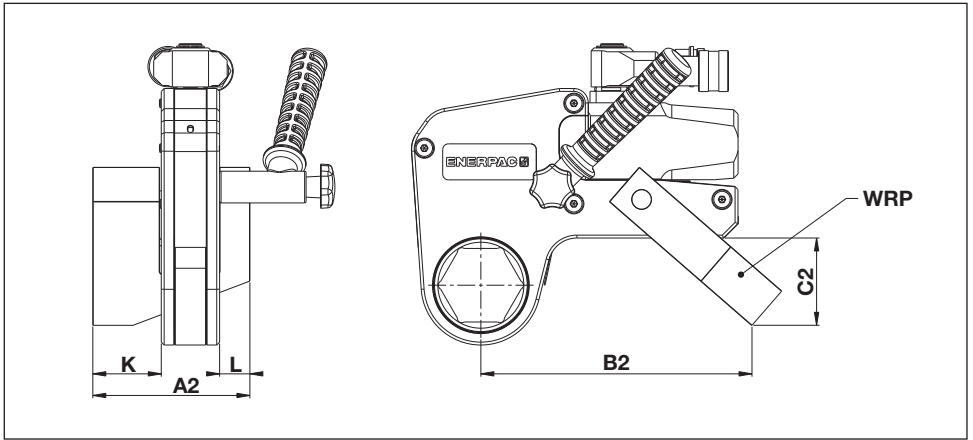

Fig. 24

## 6.1.2 Dimensions, WRP Series Reaction Paddle (Fig. 24)

Wrench Series		W2000X	W4000X	W8000X	W15000X	
Reaction Paddle Model		WRP20	WRP40	WRP80	WRP150	
Dimensions	A2	inch [mm]	3.31 [84]	4.29 [109]	5.37 [136.5]	6.50 [165]
	B2	inch [mm]	5.83 [148]	7.48 [190]	8.78 [223]	10.12 [257]
	C2	inch [mm]	1.77 [45]	2.32 [59]	2.72 [69]	3.43 [87]
	K	inch [mm]	1.40 [35.5]	1.87 [47.5]	2.25 [57]	2.74 [69.7]
	L	inch [mm]	0.63 [16]	0.83 [21]	1.02 [26]	1.26 [32]
Weight		lbs [kg]	0.88 [0.4]	1.76 [0.8]	4.41 [2.0]	8.60 [3.9]
(Reaction paddle only)						

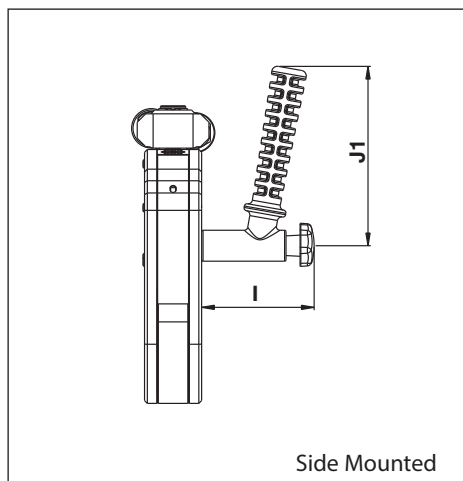

Fig. 25

## 6.1.3 Dimensions, SWH Series Angled Positioning Handle (Fig. 25)

Wrench Series			W2000X	W4000X	W8000X	W15000X
Handle Model			SWH6A	SWH6A	SWH10A	SWH10A
Dimensions	I	inch [mm]	3.15 [80]	3.15 [80]	3.62 [92]	3.62 [92]
	J1	inch [mm]	5.04 [128]	5.04 [128]	5.04 [128]	5.04 [128]

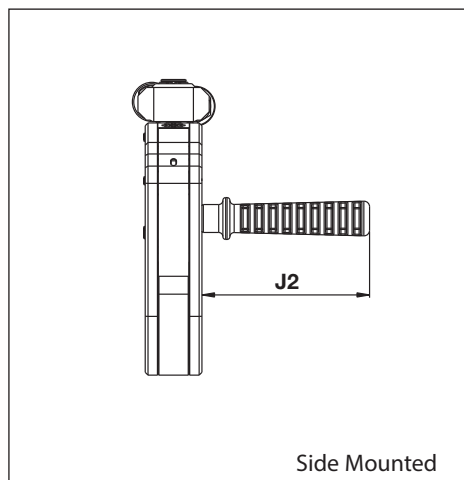

Fig. 26

#### 6.1.4 Dimensions, SWH-Series Straight Positioning Handle (Fig. 26 - optional accessory)

Wrench Series		W2000X	W4000X	W8000X	W15000X
Handle Model		SWH6S	SWH6S	SWH10S	SWH10S
Dimension J2	inch [mm]	4.72 [120]	4.72 [120]	4.72 [120]	4.72 [120]

## 6.2 Additional Cassette Specifications

### 6.2.1 Metric System Table - W2000X, W4000X and W8000X Series Cassettes (see Fig. 22 for locations of dimensions S, H and G)

Drive Unit	Cassette Model	(S) Hex size mm	(H) mm	(G) mm	Weight kg
W2000X	W2103X	30	31.0	53.7	2.1
	W2104X	32	31.0	53.7	2.1
	W2107X	36	31.0	53.7	2.4
	W2108X	38	33.5	58.2	2.4
	W2110X	41	33.5	58.2	2.4
	W2113X	46	36.5	60.5	2.4
	W2200X	50	39.0	63.1	2.4
	W2203X	55	41.8	68.6	2.5
	W2206X	60	44.5	64.8	2.5
W4000X	W4107X	36	37.0	61.0	3.7
	W4110X	41	37.0	61.0	3.7
	W4113X	46	39.5	64.0	3.8
	W4200X	50	41.5	66.7	3.9
	W4203X	55	44.0	73.4	4.6
	W4206X	60	46.5	70.6	4.6
	W4208X	63	49.5	76.2	4.7
	W4209X	65	49.5	76.2	4.7
	W4212X	70	52.5	78.3	4.7
	W4215X	75	55.5	81.6	4.7
	W4302X	80	58.5	83.5	4.8
	W4085MX	85	62.0	86.0	4.5
	W8000X	W8200X	50	45.0	78.2
W8203X		55	48.0	80.0	8.1
W8206X		60	51.0	82.5	8.1
W8209X		65	52.5	85.9	9.4
W8212X		70	56.0	84.8	9.3
W8215X		75	58.0	85.0	9.4
W8302X		80	60.5	89.5	9.3
W8085MX		85	66.0	92.2	9.8
W8090MX		90	74.0	102.9	10.6
W8312X		95	74.0	102.9	10.3
W8315X		100	78.0	108.0	9.3
W8402X		105	78.0	108.0	9.3

### 6.2.2 Metric System Table - W1500X Series Cassettes (see Fig. 22 for locations of dimensions S, H and G)

Drive Unit	Cassette Model	(S) Hex size mm	(H) mm	(G) mm	Weight kg
W1500X	W15209X	65	59.0	88.6	13.6
	W15212X	70	59.0	88.6	13.6
	W15215X	75	62.0	90.5	13.7
	W15302X	80	64.5	92.9	14.2
	W15085MX	85	69.5	96.6	14.9
	W15090MX	90	75.0	101.8	15.6
	W15312X	95	75.0	101.8	15.2
	W15315X	100	80.5	103.1	14.8
	W15402X	105	80.5	103.1	15.5
	W15405X	110	87.5	114.8	15.6
	W15115MX	115	87.5	114.8	16.1

### 6.2.3 Imperial System Table - W2000X Series Cassettes (see Fig. 22 for locations of dimensions S, H and G)

Drive Unit	Cassette Model	(S) Hex size inch	(H) inch	(G) inch	Weight lbs
W2000X	W2101X	1 1/16	1.22	2.11	4.19
	W2102X	1 1/8	1.22	2.11	4.19
	W2103X	1 3/16	1.22	2.11	4.19
	W2104X	1 1/4	1.22	2.11	4.19
	W2105X	1 5/16	1.22	2.11	4.48
	W2106X	1 3/8	1.22	2.11	4.43
	W2107X	1 7/16	1.22	2.11	4.37
	W2108X	1 7/16	1.32	2.29	4.51
	W2109X	1 9/16	1.32	2.29	4.44
	W2110X	1 5/8	1.32	2.29	4.38
	W2111X	1 11/16	1.44	2.38	4.63
	W2112X	1 3/4	1.44	2.38	4.57
	W2113X	1 13/16	1.44	2.38	4.46
	W2114X	1 7/8	1.54	2.48	4.69
	W2115X	1 15/16	1.54	2.48	4.64
	W2200X	2	1.54	2.48	4.54
	W2201X	2 1/16	1.65	2.70	4.83
	W2202X	2 1/8	1.65	2.70	4.74
	W2203X	2 3/16	1.65	2.70	4.64
	W2204X	2 1/4	1.75	2.55	4.94
	W2205X	2 5/16	1.75	2.55	4.84
	W2206X	2 3/8	1.75	2.55	4.72

## 6.2.4 Imperial System Table - W4000X Series Cassettes

(see Fig. 22 for locations of dimensions S, H and G)

Drive Unit	Cassette Model	(S) Hex size inch	(H) inch	(G) inch	Weight lbs
W4000X	W4105X	1 5/16	1.46	2.40	8.15
	W4106X	1 3/8	1.46	2.40	8.15
	W4107X	1 7/16	1.46	2.40	8.15
	W4108X	1 1/2	1.46	2.40	8.31
	W4109X	1 9/16	1.46	2.40	8.22
	W4110X	1 5/8	1.46	2.40	8.15
	W4111X	1 11/16	1.56	2.52	8.43
	W4112X	1 3/4	1.56	2.52	8.35
	W4113X	1 13/16	1.56	2.52	8.25
	W4114X	1 7/8	1.63	2.63	8.45
	W4115X	1 15/16	1.63	2.63	8.39
	W4200X	2	1.63	2.63	8.28
	W4201X	2 1/16	1.73	2.89	8.65
	W4202X	2 1/8	1.73	2.89	8.53
	W4203X	2 3/16	1.73	2.89	8.42
	W4204X	2 1/4	1.83	2.78	8.73
	W4205X	2 5/16	1.83	2.78	8.61
	W4206X	2 3/8	1.83	2.78	8.47
	W4207X	2 7/16	1.95	3.00	8.96
	W4208X	2 1/2	1.95	3.00	8.86
	W4209X	2 9/16	1.95	3.00	8.67
	W4210X	2 9/16	2.07	3.08	9.14
	W4211X	2 11/16	2.07	3.08	9.03
	W4212X	2 3/4	2.07	3.08	8.84
	W4213X	2 13/16	2.18	3.21	9.32
	W4214X	2 7/8	2.18	3.21	9.17
	W4215X	2 15/16	2.18	3.21	8.96
	W4300X	3	2.30	3.29	9.51
	W4301X	3 1/16	2.30	3.29	9.42
	W4302X	3 1/8	2.30	3.29	9.16
	W4303X	3 3/16	2.44	3.37	9.92
	W4304X	3 1/4	2.44	3.37	9.92
	W4305X	3 5/16	2.44	3.37	9.92
	W4306X	3 3/8	2.44	3.37	9.92

## 6.2.5 Imperial System Table - W8000X Series Cassettes

(see Fig. 22 for locations of dimensions S, H and G)

Drive Unit	Cassette Model	(S) Hex size inch	(H) inch	(G) inch	Weight lbs
W8000X	W8114X	1 <sup>7</sup> / <sub>8</sub>	1.77	3.08	17.97
	W8115X	1 <sup>15</sup> / <sub>16</sub>	1.77	3.08	17.89
	W8200X	2	1.77	3.08	17.75
	W8201X	2 <sup>1</sup> / <sub>16</sub>	1.89	3.15	17.52
	W8202X	2 <sup>1</sup> / <sub>8</sub>	1.89	3.15	17.36
	W8203X	2 <sup>3</sup> / <sub>16</sub>	1.89	3.15	17.22
	W8204X	2 <sup>1</sup> / <sub>4</sub>	2.01	3.25	17.92
	W8205X	2 <sup>5</sup> / <sub>16</sub>	2.01	3.25	17.76
	W8206X	2 <sup>3</sup> / <sub>8</sub>	2.01	3.25	17.59
	W8207X	2 <sup>7</sup> / <sub>16</sub>	2.07	3.38	17.65
	W8208X	2 <sup>1</sup> / <sub>2</sub>	2.07	3.38	17.52
	W8209X	2 <sup>9</sup> / <sub>16</sub>	2.07	3.38	17.29
	W8210X	2 <sup>5</sup> / <sub>8</sub>	2.20	3.34	17.50
	W8211X	2 <sup>11</sup> / <sub>16</sub>	2.20	3.34	17.36
	W8212X	2 <sup>3</sup> / <sub>4</sub>	2.20	3.34	17.12
	W8213X	2 <sup>13</sup> / <sub>16</sub>	2.28	3.35	17.57
	W8214X	2 <sup>7</sup> / <sub>8</sub>	2.28	3.35	17.38
	W8215X	2 <sup>15</sup> / <sub>16</sub>	2.28	3.35	17.11
	W8300X	3	2.38	3.52	17.77
	W8301X	3 <sup>1</sup> / <sub>16</sub>	2.38	3.52	17.65
	W8302X	3 <sup>1</sup> / <sub>8</sub>	2.38	3.52	17.33
	W8303X	3 <sup>3</sup> / <sub>16</sub>	2.60	3.63	18.99
	W8304X	3 <sup>1</sup> / <sub>4</sub>	2.60	3.63	18.72
	W8305X	3 <sup>5</sup> / <sub>16</sub>	2.60	3.63	18.54
	W8306X	3 <sup>3</sup> / <sub>8</sub>	2.60	3.63	18.36
	W8307IX	3 <sup>7</sup> / <sub>16</sub>	2.60	3.63	18.11
	W8308X	3 <sup>1</sup> / <sub>2</sub>	2.60	3.63	17.81
	W8309X	3 <sup>9</sup> / <sub>16</sub>	2.91	4.05	20.36
	W8310X	3 <sup>5</sup> / <sub>8</sub>	2.91	4.05	20.18
	W8311X	3 <sup>11</sup> / <sub>16</sub>	2.91	4.05	19.93
	W8312X	3 <sup>3</sup> / <sub>4</sub>	2.91	4.05	19.71
	W8313X	3 <sup>13</sup> / <sub>16</sub>	2.91	4.05	19.46
	W8314X	3 <sup>7</sup> / <sub>8</sub>	2.91	4.05	19.10
	W8315X	3 <sup>15</sup> / <sub>16</sub>	3.07	4.25	20.31
	W8400X	4	3.07	4.25	20.04
	W8401IX	4 <sup>1</sup> / <sub>16</sub>	3.07	4.25	19.80
	W8402X	4 <sup>1</sup> / <sub>8</sub>	3.07	4.25	19.39

## 6.2.6 Imperial System Table - W15000X Series Cassettes

(see Fig. 22 for locations of dimensions S, H and G)

Drive Unit	Cassette Model	(S) Hex size inch	(H) inch	(G) inch	Weight lbs
W15000X	W15207X	2 7/16	2.32	3.49	30.72
	W15208X	2 1/2	2.32	3.49	30.72
	W15209X	2 9/16	2.32	3.49	30.72
	W15210X	2 5/8	2.32	3.49	30.72
	W15211X	2 11/16	2.32	3.49	30.72
	W15212X	2 3/4	2.32	3.49	30.72
	W15213X	2 13/16	2.44	3.56	30.62
	W15214X	2 7/8	2.44	3.56	30.39
	W15215X	2 15/16	2.44	3.56	30.08
	W15300X	3	2.54	3.66	30.86
	W15301X	3 1/16	2.54	3.66	30.71
	W15302X	3 1/8	2.54	3.66	30.34
	W15303X	3 3/16	2.74	3.80	32.38
	W15304X	3 3/16	2.74	3.80	32.07
	W15305X	3 5/16	2.74	3.80	31.85
	W15306X	3 3/8	2.74	3.80	31.63
	W15307X	3 7/16	2.74	3.80	31.32
	W15308X	3 1/2	2.74	3.80	30.98
	W15309X	3 3/16	2.95	4.01	31.70
	W15310X	3 5/8	2.95	4.01	31.70
	W15311X	3 11/16	2.95	4.01	31.70
	W15312X	3 3/4	2.95	4.01	31.70
	W15313X	3 13/16	2.95	4.01	31.70
	W15314X	3 7/8	2.95	4.01	31.70
	W15315X	3 15/16	3.17	4.06	34.02
	W15400X	4	3.17	4.06	33.70
	W15401X	4 1/16	3.17	4.06	33.41
	W15402X	4 1/8	3.17	4.06	33.09
	W15403X	4 3/16	3.17	4.06	32.81
	W15404X	4 1/4	3.17	4.06	32.39
	W15405X	4 5/16	3.44	4.52	35.61
	W15406X	4 3/8	3.44	4.52	35.32
	W15407X	4 7/16	3.44	4.52	34.99
	W15408X	4 1/2	3.44	4.52	34.63
	W15409X	4 9/16	3.44	4.52	34.28
	W15410X	4 5/8	3.44	4.52	33.72

## 6.3 Torque Settings

### 6.3.1 Metric System Torque Factor Calculation

To set the torque, adjust the pump pressure according to the following calculation:

$$\text{Pump pressure (bar)} = \text{Torque (Nm)} / \text{Torque factor}$$

	W2000X	W4000X	W8000X	W15000X
Torque factor				
Metric system:	4.0085	8.2037	16.6432	30.1227

### 6.3.2 Metric System Pressure/Torque Table

Pump Pressure (bar)	W2000X Torque (Nm)	W4000X Torque (Nm)	W8000X Torque (Nm)	W15000X Torque (Nm)
60	241	492	999	1,807
90	361	738	1,498	2,711
120	481	984	1,997	3,615
150	601	1,231	2,496	4,518
180	722	1,477	2,996	5,422
210	842	1,723	3,495	6,326
240	962	1,969	3,994	7,229
270	1,082	2,215	4,494	8,133
300	1,203	2,461	4,993	9,037
330	1,323	2,707	5,492	9,941
360	1,443	2,953	5,992	10,844
390	1,563	3,199	6,491	11,748
420	1,684	3,446	6,990	12,652
450	1,804	3,692	7,489	13,555
480	1,924	3,938	7,989	14,459
510	2,044	4,184	8,488	15,363
540	2,165	4,430	8,987	16,266
570	2,285	4,676	9,487	17,170
600	2,405	4,922	9,986	18,074
630	2,525	5,168	10,485	18,977
660	2,646	5,414	10,984	19,881
690	2,766	5,661	11,484	20,785

**NOTICE** Torque values are rounded to the nearest whole unit.

### 6.3.3 Imperial System Torque Factor Calculation

To set the torque, adjust the pump pressure according to the following calculation:

$$\text{Pump pressure (psi)} = \text{Torque (Ft.lbs)} / \text{Torque factor}$$

	W2000X	W4000X	W8000X	W15000X
Torque factor				
Imperial system:	0.204	0.4175	0.847	1.533

### 6.3.4 Imperial System Pressure/Torque Table

Pump Pressure (psi)	W2000X Torque (Ft.lbs)	W4000X Torque (Ft.lbs)	W8000X Torque (Ft.lbs)	W15000X Torque (Ft.lbs)
1,000	204	418	847	1,533
1,500	306	626	1,271	2,300
2,000	408	835	1,694	3,066
2,500	510	1,044	2,118	3,833
3,000	612	1,253	2,541	4,599
3,500	714	1,461	2,965	5,366
4,000	816	1,670	3,388	6,132
4,500	918	1,879	3,812	6,899
5,000	1,020	2,088	4,235	7,665
5,500	1,122	2,296	4,659	8,432
6,000	1,224	2,505	5,082	9,198
6,500	1,326	2,714	5,506	9,965
7,000	1,428	2,923	5,929	10,731
7,500	1,530	3,131	6,353	11,498
8,000	1,632	3,340	6,776	12,264
8,500	1,734	3,549	7,200	13,031
9,000	1,836	3,758	7,623	13,797
9,500	1,938	3,966	8,047	14,564
10,000	2,040	4,175	8,470	15,330

**NOTICE** Torque values are rounded to the nearest whole unit

## 7 Replacement parts and recommended tools

### 7.1 Ordering Replacement Parts

For replacement parts information, refer to the Enerpac repair parts sheet for your wrench model. Repair parts sheets are available on the internet at [www.enerpac.com](http://www.enerpac.com).

Have the following information ready when ordering replacement parts:

- Wrench model and serial numbers (for both drive unit and cassette).
- Approximate date of purchase.
- Part number and description of each part being ordered.

### 7.2 Recommended Tool Kit, W2000X Series

- 7/8" A/F Spanner
- 3/4" A/F Spanner
- 5/8" A/F spanner
- Circlip Pliers
- Seal Extraction Tool
- 16 mm A/F Spanner
- ø 4 mm x 5 mm LG x 20 mm PCD Pin Spanner
- 5 mm A/F Allen Key
- 3 mm A/F Allen Key
- 2.5 mm A/F Allen Key
- 3 mm Terminal Screwdriver

### 7.3 Recommended Tool Kit, W4000X Series

- 7/8" A/F Spanner
- 3/4" A/F Spanner
- 5/8" A/F Spanner
- Circlip Pliers
- Seal Extraction Tool
- ø 4 mm x 5 mm LG x 25 mm PCD Pin Spanner

- 6 mm A/F Allen Key
- 4 mm A/F Allen Key
- 2.5 mm A/F Allen Key
- 3 mm Terminal Screwdriver

### 7.4 Recommended Tool Kit, W8000X Series

- 7/8" A/F Spanner
- 3/4" A/F Spanner
- 5/8" A/F Spanner
- Circlip Pliers
- Seal Extraction Tool
- 1 1/8" A/F Spanner
- ø 4 mm x 5 mm LG x 30 mm PCD Pin Spanner
- 10 mm Allen Key
- 5 mm A/F Allen Key
- 4 mm A/F Allen Key
- 2.5 mm A/F Allen Key
- 3 mm Terminal Screwdriver

### 7.5 Recommended Tool Kit, W15000X Series

- 7/8" A/F Spanner
- 3/4" A/F Spanner
- 5/8" A/F Spanner
- Circlip Pliers
- Seal Extraction Tool
- 1 3/8" A/F Spanner
- ø 4 mm x 5 mm LG x 40 mm PCD Pin Spanner
- 10 mm A/F Allen Key
- 6 mm A/F Allen Key
- 4 mm A/F Allen Key
- 2.5 mm A/F Allen Key
- 3 mm Terminal Screwdriver

Notes:

A/F = Across Flats

PCD = Pitch Circle Diameter



[www.enerpac.com](http://www.enerpac.com)

---