

Repair Parts Sheet	Revision	Revision Date	Product Code Beginning
Reference nr. L2853	C	08/2022	C

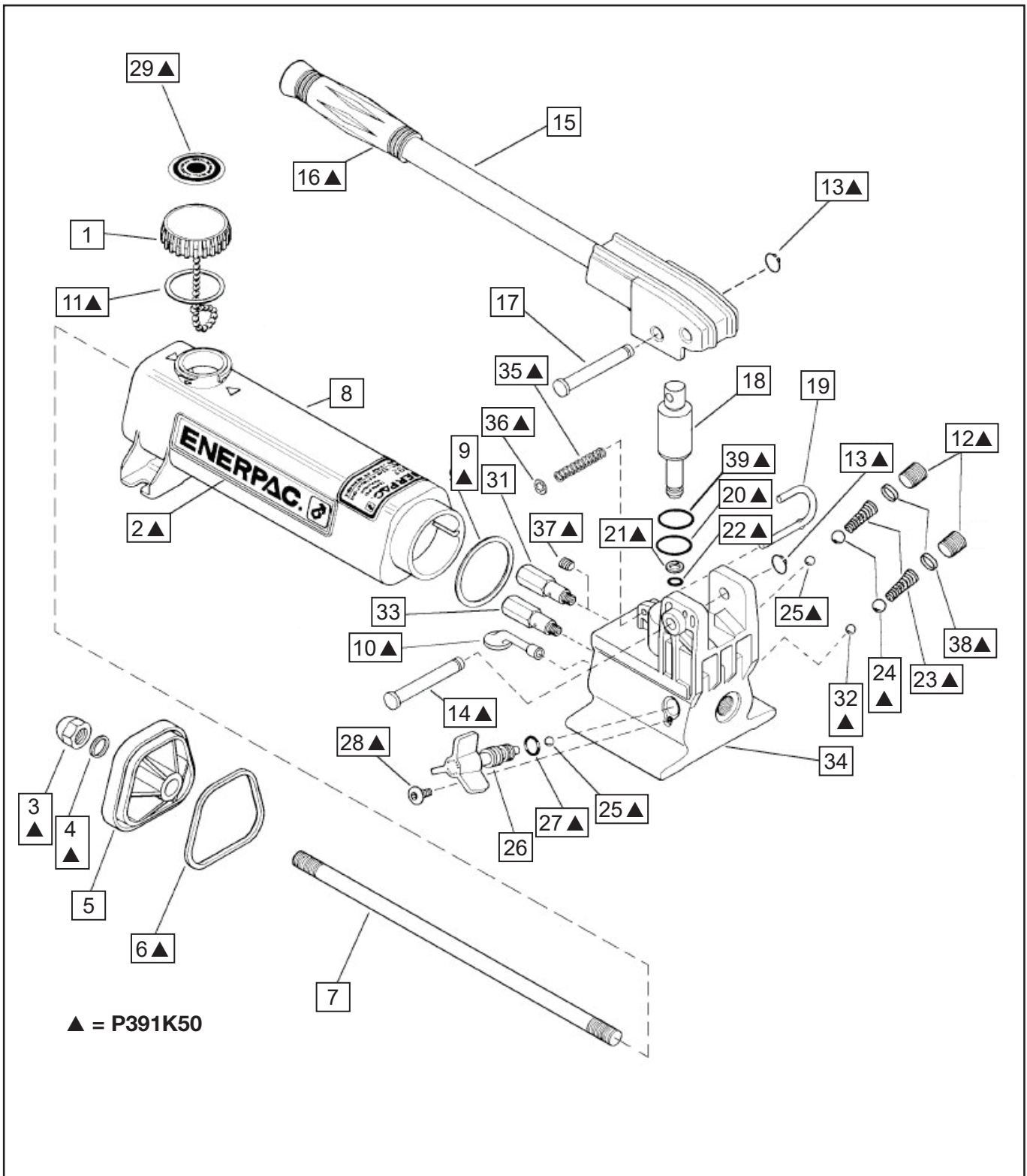

Repair Parts List					L2853
Item	Description	Qty.	P391	Qty.	P392
1	Vent Cap Assy (incl. 11,29)	1	CN766950SR	1	CN766950SR
2	Enerpac Decal	2	▲	2	▲
3	Acorn Nut	1	▲	1	▲
4	Gasket	1	▲	1	▲
5	End Cap (incl. 3,4,6)	1	CN814020SR	1	CN814020SR
6	Gasket O Ring	1	▲	1	▲
7	Tie Rod	1	CL127149	1	CL127149
8	Reservoir Yellow (incl. 2,3,4,6,9,11)	1	CR72025SR	1	CR72025SR
9	Gasket	1	▲	1	▲
10	Oil Filter	1	▲	1	▲
11	Gasket	1	▲	1	▲
12	Pipe Plug	2	▲	2	▲
13	Retaining Ring	2	▲	2	▲
14	Beam Pin	1	▲	1	▲
15	Beam and Handle Assy	1	CL918900SR	1	CL918900SR
16	Handle Grip	1	▲	1	▲
17	Cross Pin	1	DC106061SR	1	DC106061SR
18	Plunger Assy (incl. 13,17,21,22)	1	CR333040SR	1	CR333040SR
19	Lock Pin (incl. 35,36)	1	▲	1	▲
20	O Ring	1	▲	1	▲
21	Back Up Ring	1	▲	1	▲
22	O Ring	1	▲	1	▲
23	Spring	2	▲	2	▲
24	Delivery Ball	1	▲	2	▲
25	Suction Ball	1	▲	2	▲
26	Spindle assy (incl. 25,27,28)	1	CL913900SR	1	CL913900SR
27	O Ring	1	▲	1	▲
28	Screw	1	▲	1	▲
29	Vent Cap Decal	1	▲	1	▲
31	Bypass Valve	0	-	1	DA5493900SR
32	Inlet Check Ball	0	-	1	▲
33	Relief Valve	1	DA8802900SR	1	DA8802900SR
34	Base	Not available, order a new pump			
35	Spring	1	▲	1	▲
36	Retaining Ring	1	▲	1	▲
37	Pipe Plug	1	▲	0	-
38	Spring Cap	2	▲	2	▲
39	Wiper	1	▲	1	▲

▲ = Indicates items included in and available only as part of Repair kit P391K50



Item	Torque / remark
3	20 Nm -15 Ft lbs
12	38 - 46 Nm 28 - 34 Ft lbs
18	Apply bearing greas to contact surfaces of pin and plunger
25	Item 25 low pressure inlet ball not used in P391
31, 37	14 - 16Nm 10 - 12 Ft lbs (Item 31 only used in P392)
33, 37	14 - 16 Nm 10 - 12 Ft lbs
37	Plug item 37 is used instead of bypass valve 31 in P391

Item	Relief valve setting
31	14 - 19 Bar 200 - 275 Psi (only used in P392)
33	690 - 724 Bar 10 000 - 10 500 Psi