

L2078 Rev. K 01/23

**PUD1100B, PUD1101B: For Date Codes Beginning with the Letter “H”**  
**PUD1100E, PUD1101E: For Date Codes Beginning with the Letter “G”**

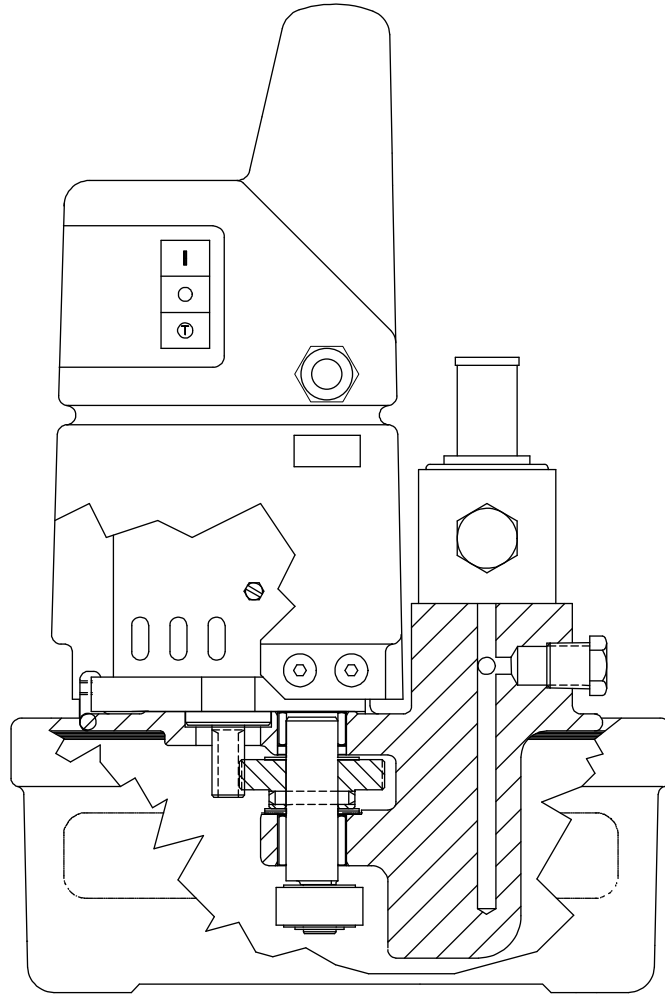

**Contents:**

Figure 1 - Pump Side View .....	2	Figure 9 - Shroud Wiring-Left of Motor .....	5
Figure 2 - Pump Front View (shroud removed).....	2	Figure 10 - Shroud Wiring-Right of Motor.....	5
Figure 3 - Relief Valve.....	2	Figure 11 - Top View-Cord and Cables .....	6
Figure 4 - Pump Bottom View .....	2	Figure 12 - Pendant Assembly .....	7
Figure 5 - Pump Front View (assembled) .....	3	Figure 13 - Poppet Valve Assembly .....	8
Figure 6 - Pump Top View .....	4	Figure 14 - Electrical Schematic, 115V Models .....	8
Figure 7 - Shroud Wiring-Behind Motor .....	5	Figure 15 - Electrical Schematic, 230V Models.....	9
Figure 8 - Shroud Wiring-Front of Motor .....	5		

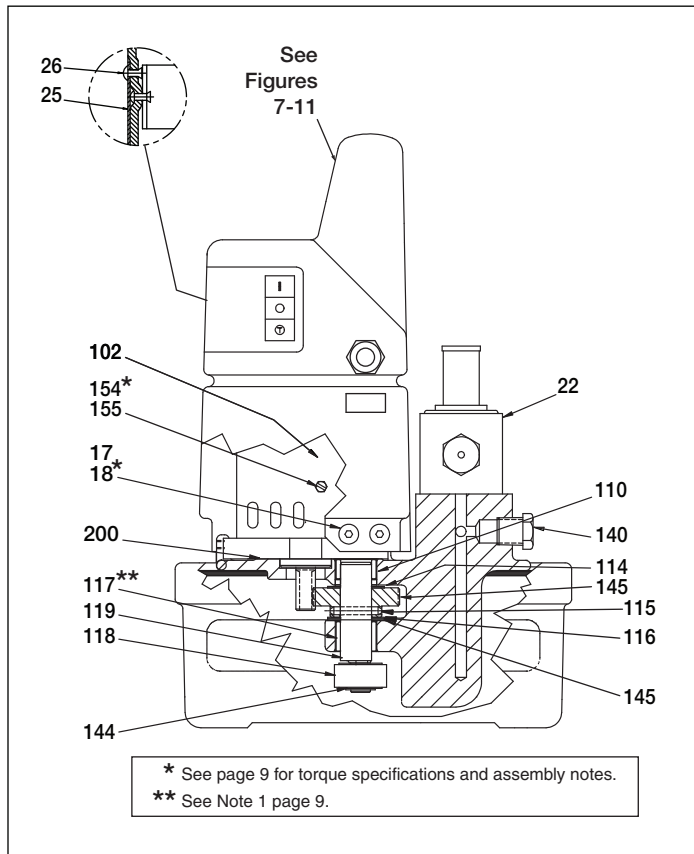

**Figure 1, Pump Side View**

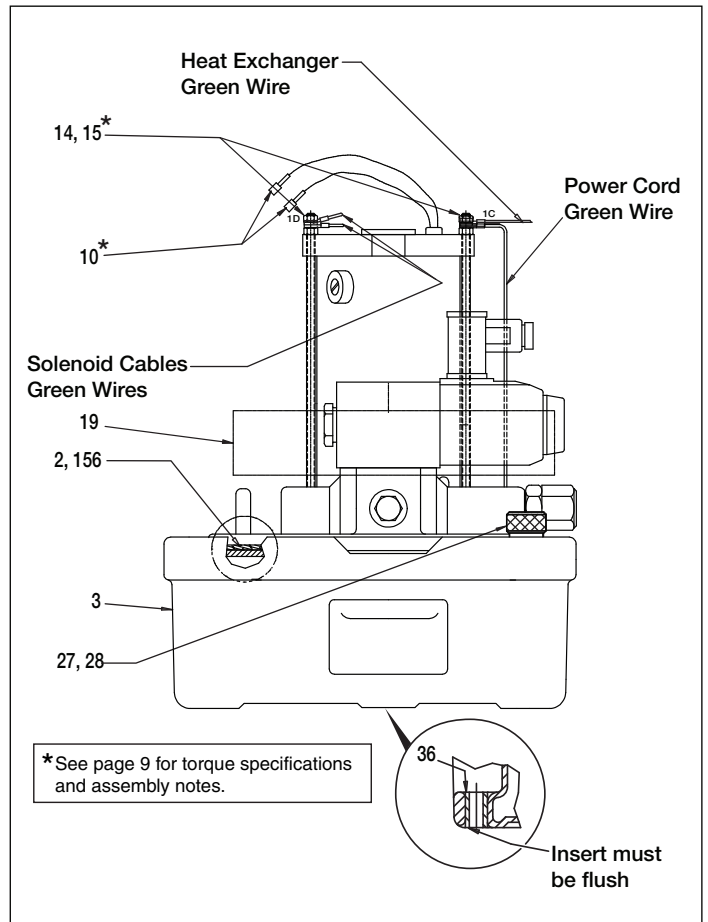

**Figure 2, Pump Front View (shroud removed)**

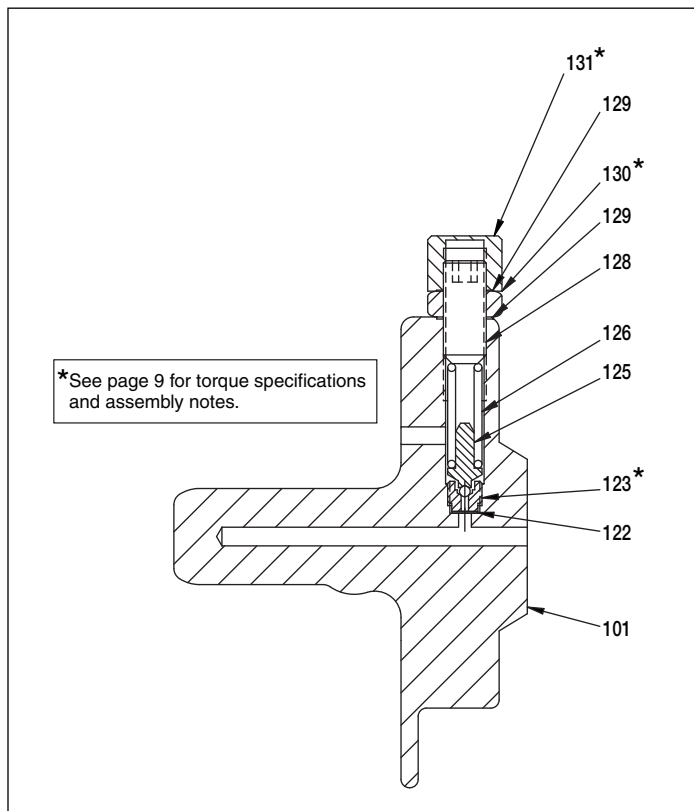

**Figure 3, Relief Valve**

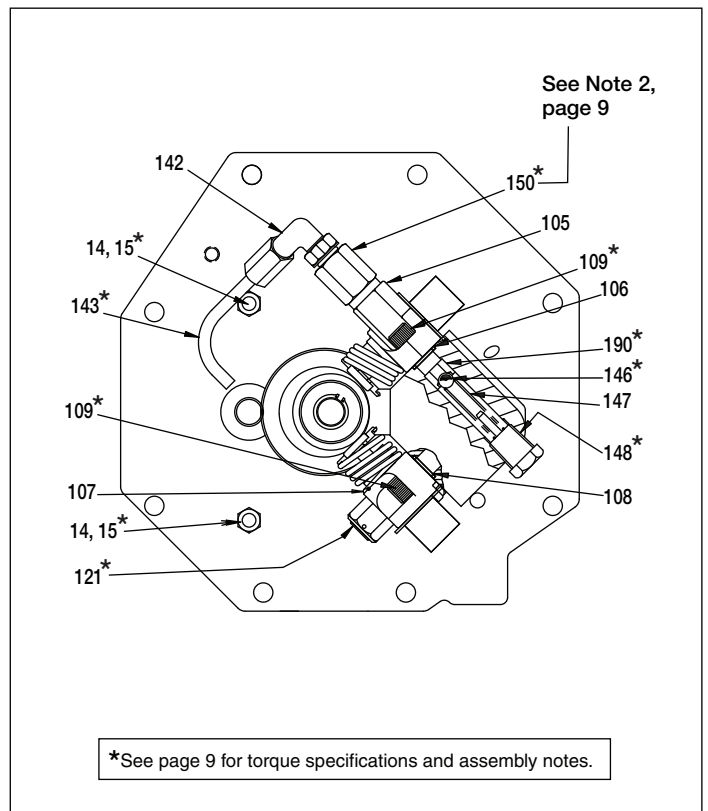

**Figure 4, Pump Bottom View**

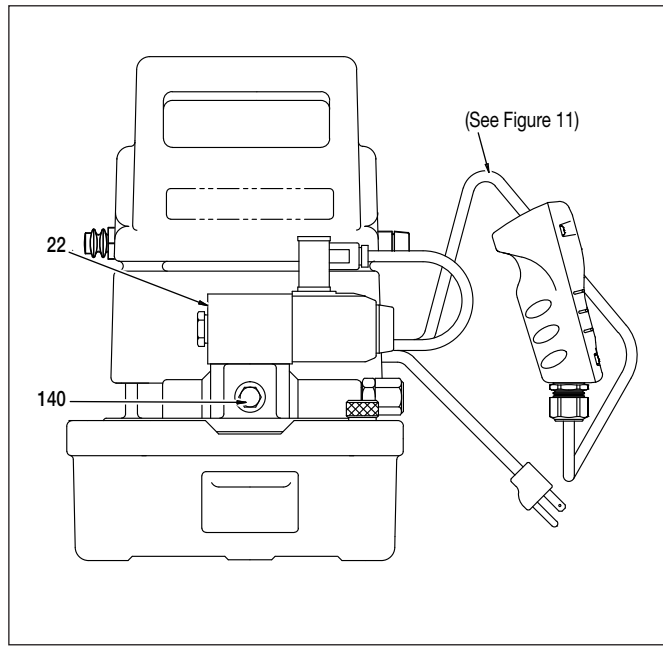

**Figure 5, Pump Front View (assembled)**

**Repair Parts List for Figures 1 through 5**

Item	Part Number	Qty.	Description
2	H DA12088167SR	1	Gasket (Includes item 156)
3	DA1910900SR	1	Reservoir Assembly. 0.5 Gal.
	DA4780900SR		Reservoir Assembly. 1.0 Gal.
10	DA3776006	2	Pin
14	DA15066	4	Lock Washer
15	B1018121	4	Hex Nut
17	CW261225	6	Eyelet
18	F866028	6	Machine Screw
19	CW259298	1	Baffle
22	VSG2310P	1	115V Poppet Valve Assy
	VSG3510P	1	230V Poppet Valve Assy
25	Contact Enerpac	1	Nameplate
26	DC818003	4	Pop Rivet
27	DA608024	1	Vent Plug
28	H B1906503	1	O-Ring
36	DA931225	2	Insert
101	DA12490840SR	1	Pump Manifold (includes # 121)
102	CW179259	1	115 VAC Motor
	DC1415259	1	230 VAC Motor (50 Hz)
105	DD1449051SR	1	Piston Block Assembly, 14mm
106	H B1007503	1	O-Ring
107	DD1450051SR	1	Piston Block Assembly, 6mm
108	H B1012803	1	O-Ring
109	B1010028X	4	Screw
110	CW252107	1	Bearing
114	CW301228	1	Driven Gear
115	H B1097057	1	Spring Pin
116	H CW199107	1	Bearing
117	CW251107	1	Bearing

☐ Included in Repair Kit PUD1100BK

Item	Part Number	Qty.	Description
118	CW302107	1	Bearing
119	CW303104	1	Shaft
121	DA5999900SR	1	Relief Valve (see Figure 4)
122	H C846037	1	Gasket
123	H DA5771290	1	Seat
125	DC1316900SR	1	Ball Guide Assembly
126	H A109164	1	Compression Spring
128	DA252028	1	Adjusting Screw
129	H S1167	1	Gasket
130	CW306055	1	Lock Nut
131	CW307055	1	Cap Nut
140	R515245-2	1	Plug
142	DA1011096	1	Elbow
143	DA261268	1	Tube
144	H CW467044	1	Retaining Ring
145	H DA445107	2	Bearing
146	H B1007016	1	Ball
147	H DA1564110	1	Spring
148	DC433950	1	Plug Assembly
149	B1020028	4	Cap Screw
150	DA610900SR	1	Relief Valve Assembly
154	H CU876028	3	Screw (10-24)
155	DA3585186	3	Spacer
156	See item 2	1	Gasket
190	DA12352290	1	Ball Seat
200	H DC1947167	1	Gasket

**Replacement Brushes for Electric Motor**

---	DA9655380	1	Brush Set for 115V Models
---	DA9656380	1	Brush Set for 230V Models

\* See page 9 for torque specifications and assembly notes.

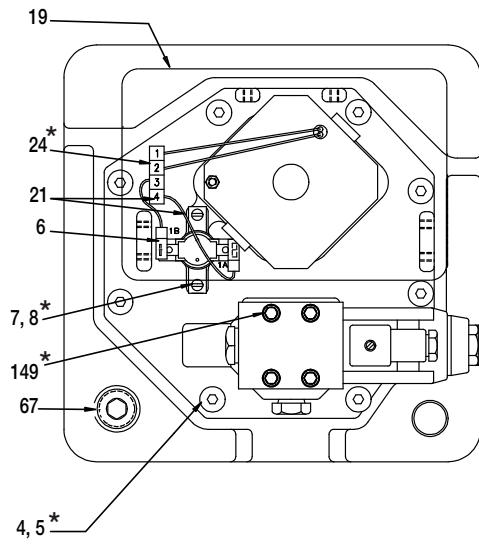
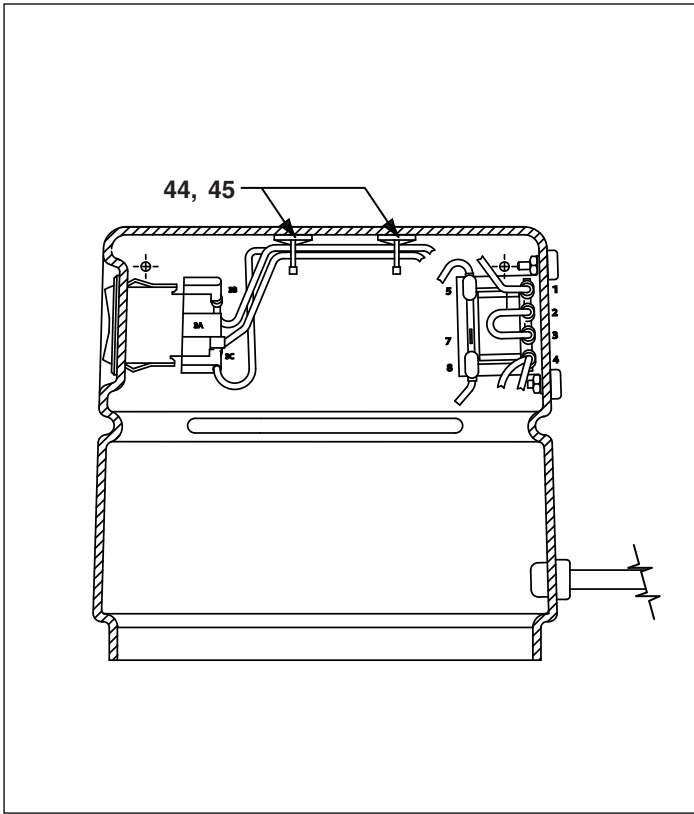

Figure 6, Pump Top View

### Repair Parts List for Figure 6

Item	Part Number	Qty.	Description
4	DA6954167	8	Gasket
5	DC2038028	8	Screw
6	E1100004	1	Thermostat, 115V
	DC8401372	1	Thermostat, 230V
7	C701222	2	Washer
8	M642028	2	Screw
19	CW259298	1	Baffle
21	DC7969960	2	Wire Assembly
24	DA11540380	1	Pin Housing
67	A1009245	2	Plug
149	DD1074028	4	Cap Screw



**Figure 7, Shroud Wiring - Behind Motor**

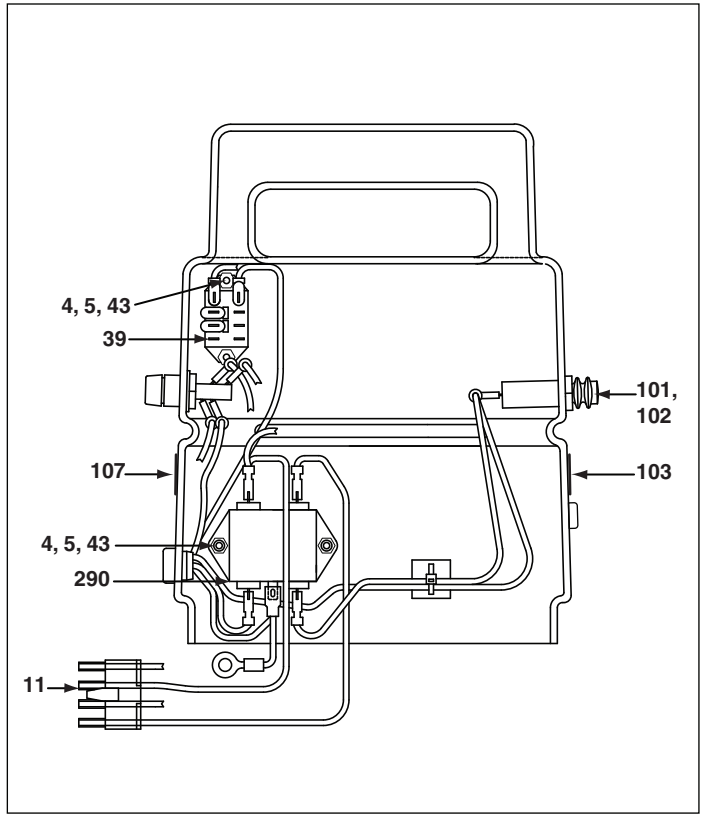

**Figure 8, Shroud Wiring - Front of Motor**

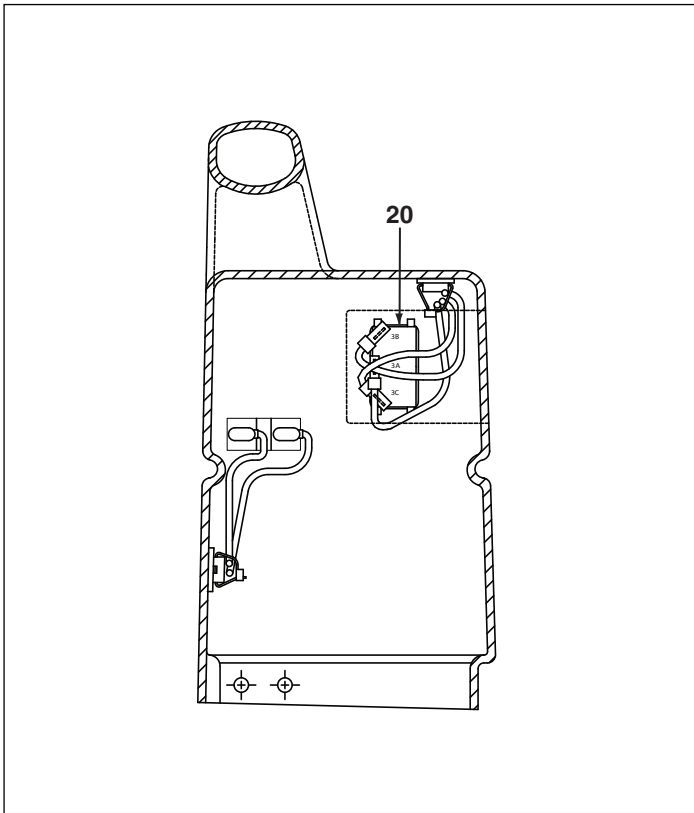

**Figure 9, Shroud Wiring - Left of Motor**

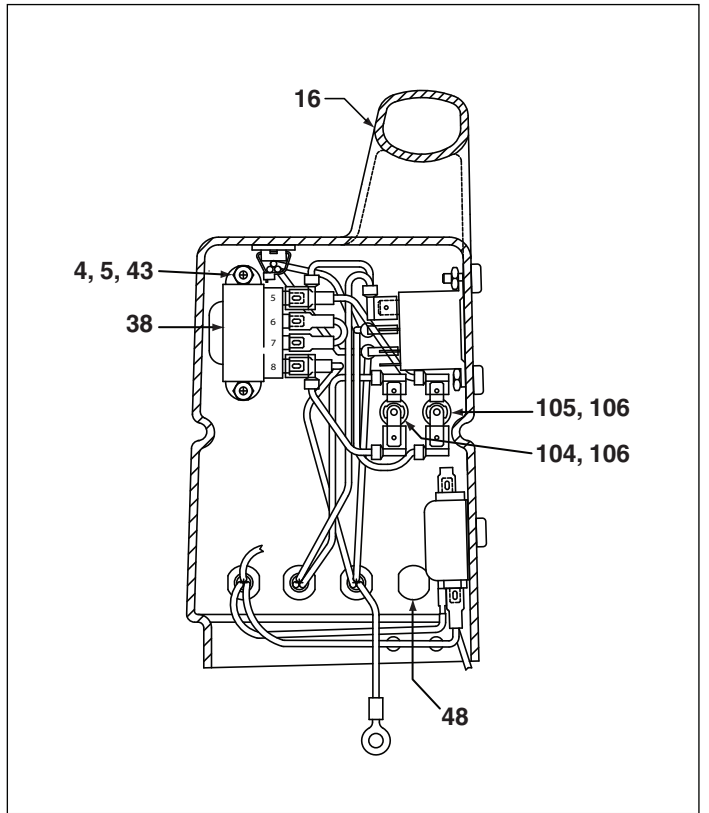

**Figure 10, Shroud Wiring - Right of Motor**

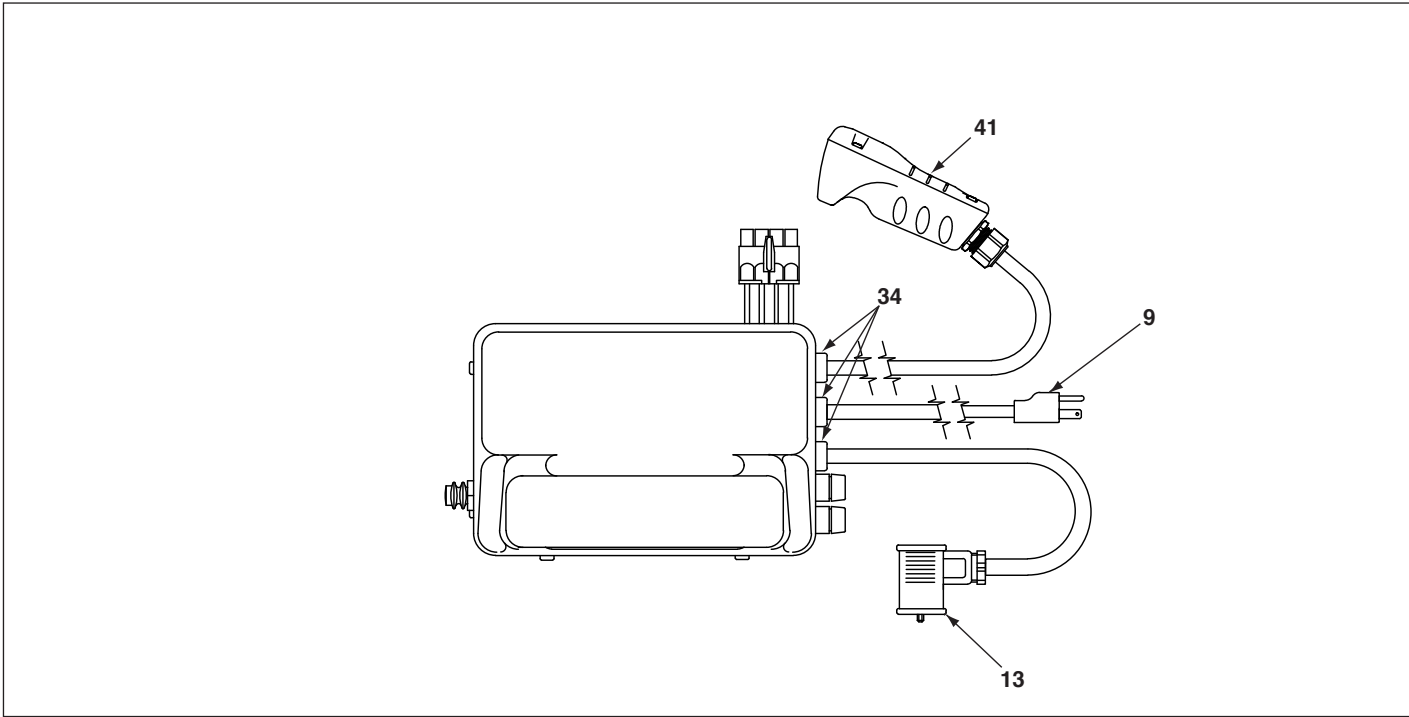
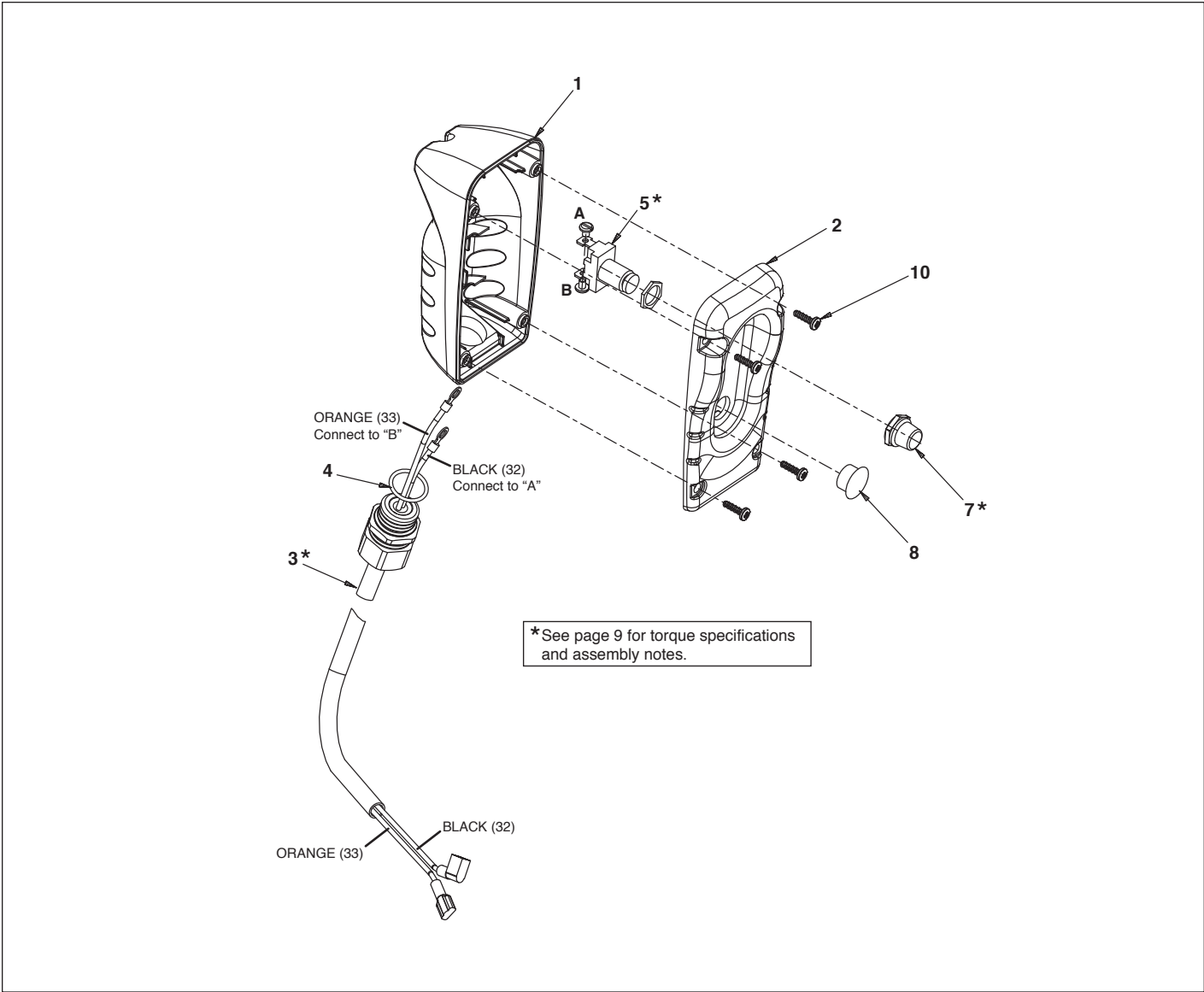

Figure 11, Top View, Cord and Cables

Repair Parts List for Figures 7 through 11

Item	Part Number	Qty.	Description	Item	Part Number	Qty.	Description
4	BC1310728	4	Screw (115V)	43	DA5974098	4	Screw Cover (115V)
	BC1310728	6	Screw (230V)		DA5974098	6	Screw Cover (230V)
5	F75021	4	Lock Nut #6-32 (115V)	44	EHC3901075	3	Tie Down, Self Adhesive
	F75021	6	Lock Nut #6-32 (230V)	45	DA3131217	4	Cable Tie
9	DC7954960SR	1	Power Cord, 115V	101	DC8366380	1	Circuit Breaker (115V)
	DD5840960SR	1	Power Cord, 230V		DC8367380	1	Circuit Breaker (230V)
11	DA11539380	1	Receptacle	102	DC8200380	1	Circuit Breaker Reset Cap
13	DC7911960SR	1	Solenoid Cable	103	DC8237023	1	Circuit Breaker Decal
	DC10037098	1	Shroud (115V)	104	DC8371378	1	Secondary Fuse, 300mA
16	DC10036098	1	Shroud (230V)	105	DC8370378	1	Primary Fuse, 62mA (115V)
	E1500002	1	Switch		DC8400378	1	Primary Fuse, 40mA (230V)
34	CR759291	3	Cord Bushing	106	DC8372378	2	Fuse Holder
38	DA5875380	1	Transformer	107	DC7891026	1	Fuse Decal
39	DD2668380	1	Relay (115V)	290	DC8365380	1	EMI Filter (230V only)
	DC8280980	1	Relay (230V)				
41	DD2686900SR	1	Pendant Assy (115V)				
	DD1048900SR	1	Pendant Assy (230V)				

Note: For replacement shroud assembly, order Repair Kit DC7944900SR (115V) or DC7945900SR (230V).



**Figure 12, Pendant Assembly**

Repair Parts List for Figure 12							
Item	Part Number	Qty.	Description	Item	Part Number	Qty.	Description
1	DC9425424	1	Assembly, Lower Pendant	5	DC8282379	1	Switch, Push Button
2	DC8122424	1	Assembly, Upper Pendant	7	DC8284379	1	Boot, Push Button
3	DD2684960	1	Pendant Cord (115V Models)	8	DC8228009	1	Dome Plug, 1/2"
	DD1053960	1	Pendant Cord (230V Models)	10	DC9428008	4	Screw, Hi-Lo #8 x1/2"
4	B1223503	1	O-Ring				

Complete replacement pendant assembly (includes all items shown in Fig. 12):

- 115V Models: order Repair Kit DD2686900SR.
- 230V Models: order Repair Kit DD1048900SR.

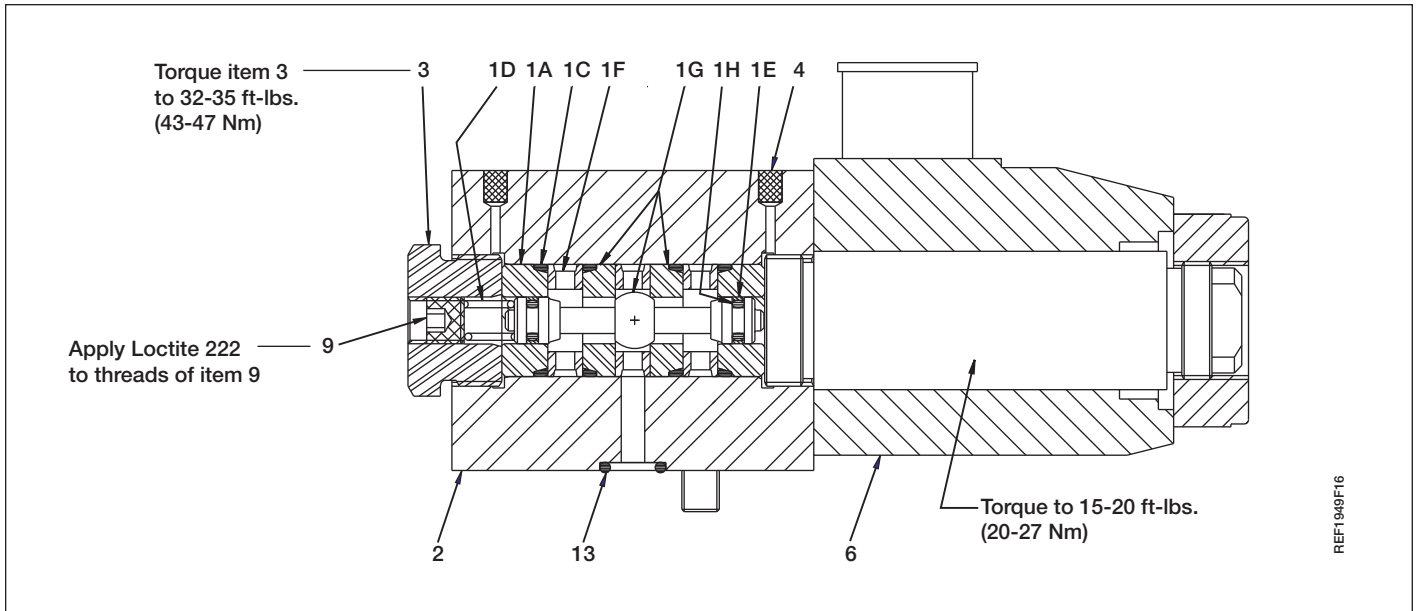

Figure 13, Poppet Valve Assembly

Repair Parts List for Figure 13							
Item	Part Number	Qty.	Description	Item	Part Number	Qty.	Description
1	DA5792949SR	1	Valve Stack (inc. items 1A-1H)	2	DA4393190	1	Valve Block Body
1A	DA3697039	2	Bushing	3	DA5421009	1	Valve Plug
1C	B1016803	4	O-ring	4	DA4390118	2	Filter
1D	DA5422110	1	Comp. Spring	6	DA4405900	1	Solenoid Assembly (115V)
1E	CH279044	2	Glyd Ring		DA5714900	1	Solenoid Assembly (230V)
1F	DA3698290	3	Seat Spacer	9	PA1417027	1	Set Screw
1G	DC862949	1	Poppet Set	13	B1011803	3	O-Ring
1H	B1002503	2	O-Ring				

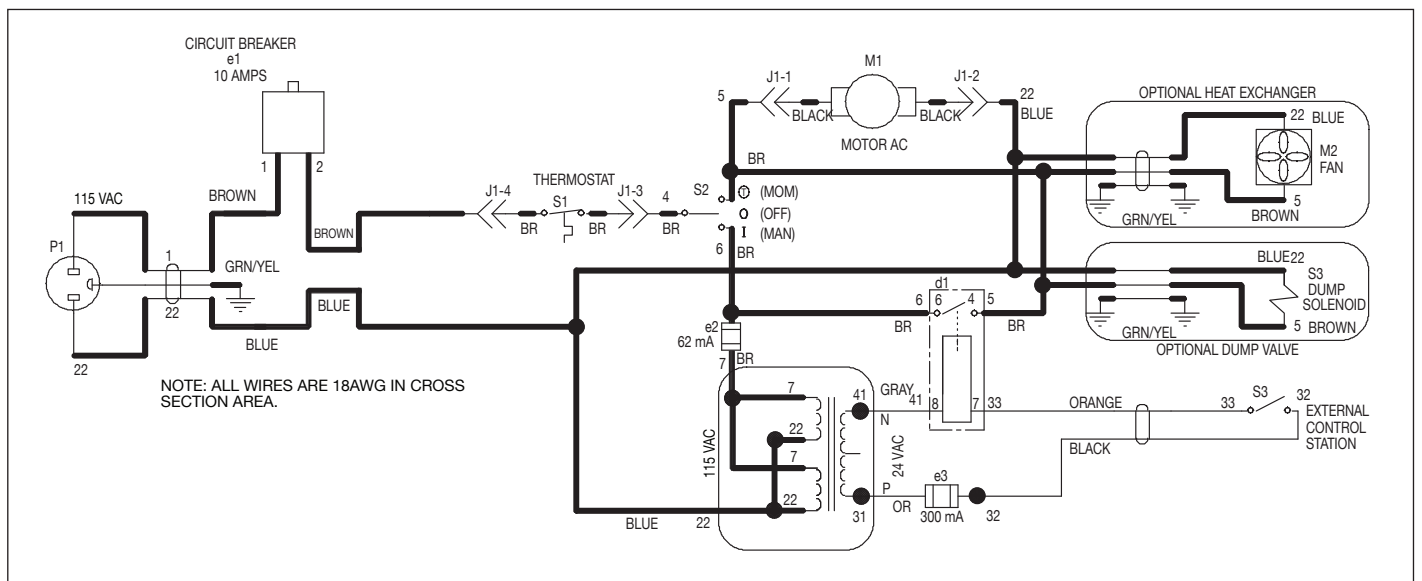

Figure 14, Electrical Schematic, 115V Models



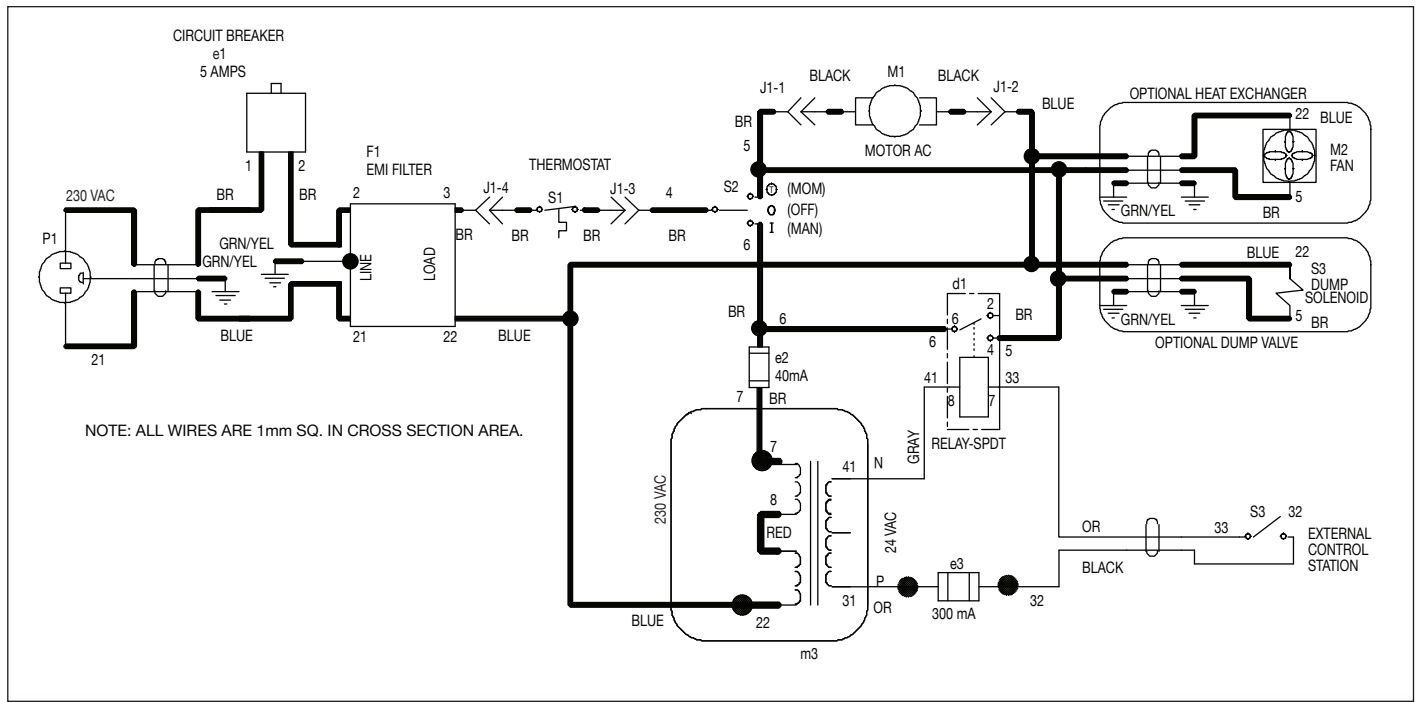

Figure 15, Electrical Schematic, 230V Models

Figure	Item No.	Torque Specification and/or Assembly Notes
1	18	Apply 1 drop Loctite #242 to threads. Torque to 12 to 18 in-lbs (1,4 to 2,0 Nm).
1	154	Torque to 27-31 in-lbs (3,1 to 3,5 Nm).
1	Note 1	Install bearing, Item 117, flush to 0.010" (2,54 mm) recessed from surface.
2	10	Trim wire length to 9 to 10 inches (228 - 254 mm) before attaching pins (item 10). Then insert into item 24.
2	15	Torque to 27 to 31 in-lbs, (3,1 to 3,5 Nm).
3	123	Torque to 15 to 16 ft-lbs (20,0 to 21,7 Nm) lubricated.
3	130,131	Torque to 15 to 20 ft-lbs (20 to 27 Nm).
4	15	Torque to 27-31 in-lbs (3,1 to 3,5 Nm).
4	109	Torque to 14 to 16 ft-lbs, dry (19,0 to 21,7 Nm).
4	121	Torque to 16-19 ft-lbs, dry (21,7 to 25,8 Nm).
4	143	Align tube to face mesh and splash lubricate upper needle bearing.
4	146	Seat must be coined prior to assembly.
4	148	Assemble with Loctite #545.
4	150	Relief valve setting should be from 250 to 400 psi (17,3 to 27,9 bar).
4	190	Assemble with Loctite #609.
4	Note 2	Stake threads after setting pressure.
6	149	Torque to 8 to 10 ft-lbs (10,8 to 13,5 Nm).
6	5	Torque to 47-53 in-lbs (5,3 to 6,0 Nm). Use Loctite #242 on item #5.
6	8	Torque to 9-12 in-lbs (1,0-1,3 Nm).
6	24	Attach to receptacle on shroud.
12	3, 5	Connect black wire of pendant cord (labeled "32") to terminal "A" of switch. Connect orange wire of pendant cord (labeled "33") to terminal "B" of switch.
12	5	Torque switch screw terminals to 5.0-5.5 in-lbs (0,56-0,62 Nm) after making connections.
12	7	Torque to 14-16 in-lbs (1,6-1,8 Nm).

