

To Protect Your Warranty, Use Only ENERPAC Hydraulic Oil.

Enerpac recommends that all kit components be installed to insure optimum performance of the repaired product.

Note: The pipe plug, item 37, is used in place of the by-pass valve, item 31, in the P-141.

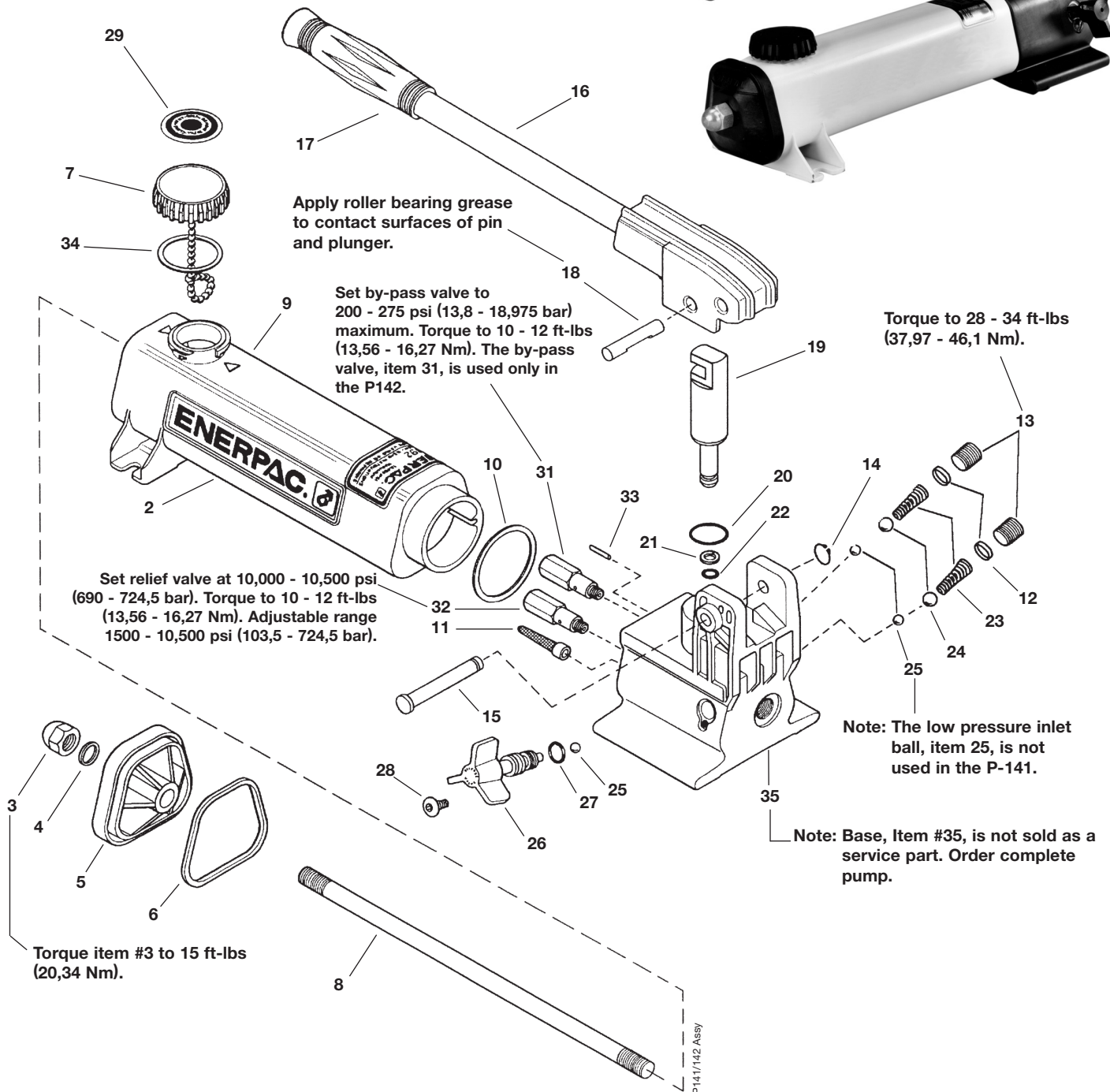

Repair Parts List

Item	Part Number	Qty.	Description	Item	Part Number	Qty.	Description
2	★CN767026	2	Enerpac Decal	18	P20857	1	Cross Pin
	DC1797026	2	Enerpac Decal (models 1001, 1002)	19	CN412040SR	1	Plunger (incl. item 20,21,22,30)
3	CL341055	1	Acorn Nut	20	★B1018803	1	O-Ring
4	★CU293167	1	Gasket	21	★B1010564	1	Back-Up Washer
5	CN402020SR	1	End Cap (incl. items 3,4,6)	22	★B1010803	1	O-Ring
6	★B1141517	1	Square Ring	23	★DA1176210	2	Spring
7	CN766950SR	1	Vent Cap Assembly (incl. items 29,34)	24	★B1009016	2	5/16" Ball
8	CL280149	1	Tie Rod	25	★B1006016	3	7/32" Ball
9	CN782025SR	1	Reservoir (yellow incl. items 2,3,4,6,10,34)	26	CL913900SR	1	Spindle Assembly (inc. item 25,27,28)
	DA3886025		Reservoir (red incl. items 2,3,4,6,10,34)	27	★B1007503	1	O-Ring
10	★B1131517	1	Square Ring Seal	28	★CU921028	1	Truss Head Machine Screw
11	★CB981018	1	Filter	29	★CN780026	1	Fill Decal
12	★DA3702020	2	Spring Cap	31	DA5493900SR	1	Bypass Valve (models P142 and 1002)
13	CN815006	2	Pipe Plug (.250 - 18 N.P.T.F.)	32	DA8802900SR	1	Relief Valve (10,000 - 10,500 PSI)
14	★DA1178349	1	Retaining Ring	33	★B1036057	1	Spring Pin
15	★CR215061SR	1	Beam Pin (incl. item 14)	34	★CU724167	1	Vent Cap Gasket
16	CL915900SR	1	Beam and Handle Assembly	35	DA5483005	1	Pump Base
17	CL342550	1	Handle Grip	37	A1006245	1	Pipe Plug (P141 only)

★ Indicates items included in Repair Kit P141K2. For Viton seals, order Repair Kit P142KV1 in place of standard kit P141K2. (Kit contains 2 sets of seals; be sure to replace with identical seal as the one removed from the pump.)



www.enerpac.com