

L1787
REV B
09/97
PC5410

DATE CODES BEGINNING WITH THE LETTER "O".

MODEL NUMBER CODE

- | | | | | | | | |
|--------------------------------------|----------------------|--------------------------------------|----------------------|--------------------|---------------------|---------------------------|--------------------------|
| 1 | 2 | 3 | 4 | 5 | 6 | 7 | 8 |
| 1. S = swing cylinder | 2. T = threaded body | 3. R = right swing
L = left swing | 4. D = double-acting | 5. L = long stroke | 6. 12 = 12 kN force | 7. 1 = imperial body type | 8. V = Viton seal option |
| U = upper flange
L = lower flange | | S = straight swing | | | | | |

NOTE: You may need special tools to reassemble these swing cylinders. Tool drawings are available on request from Enerpac. To obtain tool drawings, contact the Enerpac Technical Services Department at 1-800-433-2766. Please be prepared to provide the Model Number and the Manufacturing Date Code of each swing cylinder being serviced.

THREADED BODY MOUNTING STYLE

Setting Rotation Direction

- When inserting plunger into base, align desired letter to arrow head stamped on side of cylinder body.
R=right swing rotation
L=left swing rotation
S=straight (no rotation)
- Insert plunger with proper tools. You may have to turn the plunger as you insert it to properly align ball in groove.

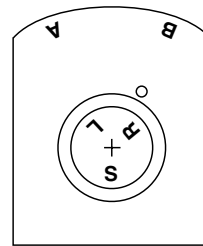

Top View

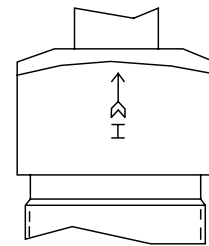

Front View

Single-Acting Models

- Lubricate all seals with Lubriplate prior to assembly.
- Lubricate ball and washer (items 18 & 19) with Lubriplate.
- Torque stop ring (item 2) to 8-15 ft-lbs (11-20 Nm).

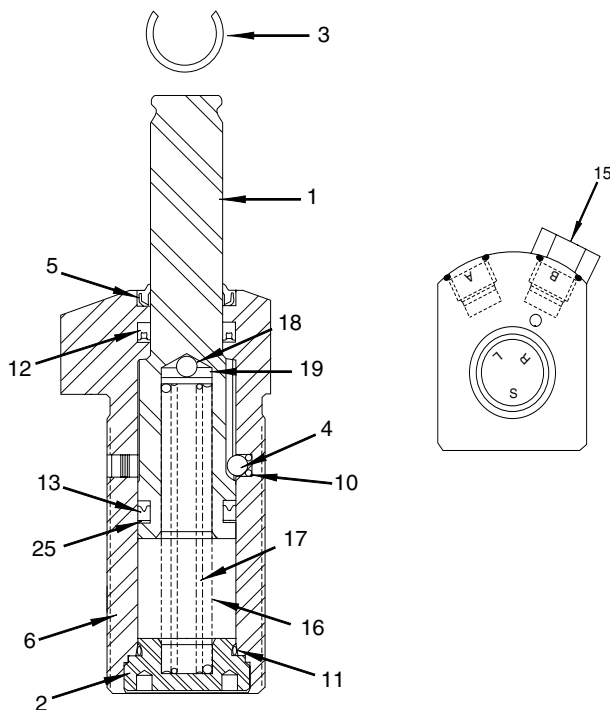

Double-Acting Models

- Lubricate all seals with Lubriplate prior to assembly.
- Torque stop ring (item 2) to 8-15 ft-lbs (11-20 Nm).

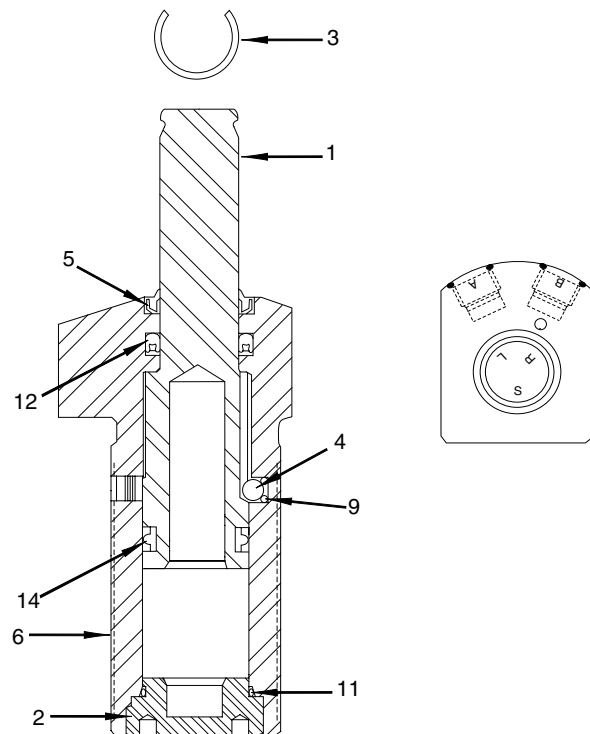

LOWER FLANGE MOUNTING STYLE

Setting Rotation Direction

- When inserting plunger into base, align desired letter to arrow head stamped on side of cylinder body.
 R=right swing rotation
 L=left swing rotation
 S=straight (no rotation)
- Insert plunger with proper tools. You may have to turn the plunger as you insert it to properly align ball in groove.

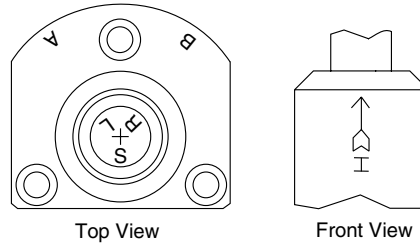

Single-Acting Models

- Lubricate all seals with Lubriplate prior to assembly.
- Lubricate ball and washer (items 18 & 19) with Lubriplate.
- Torque stop ring (item 2) to 8-15 ft-lbs (11-20 Nm).

Double-Acting Models

- Lubricate all seals with Lubriplate prior to assembly.
- Torque stop ring (item 2) to 8-15 ft-lbs (11-20 Nm).

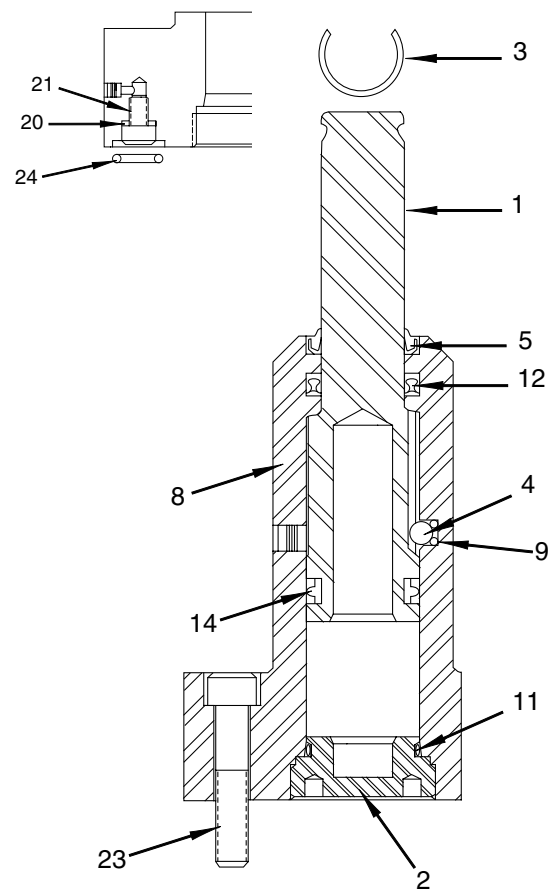
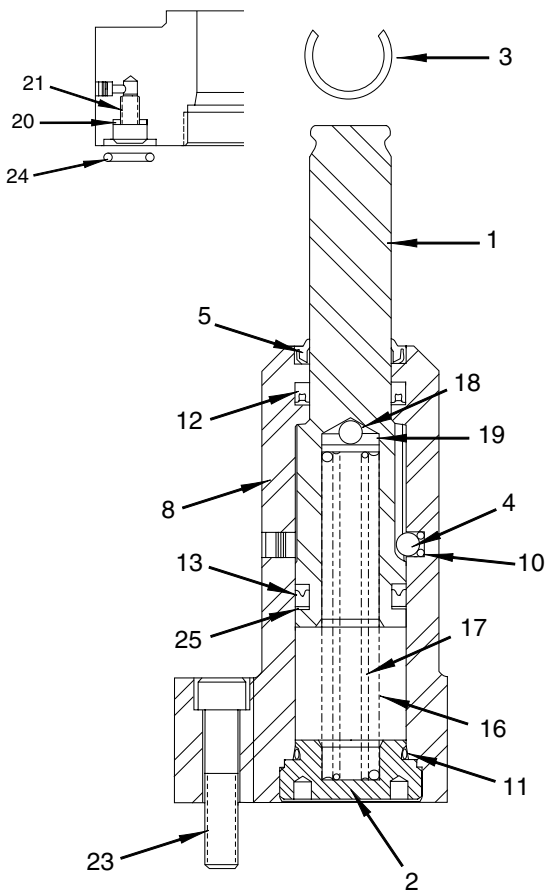
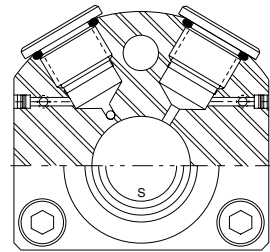
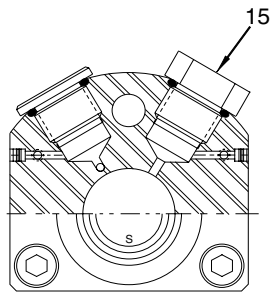

UPPER FLANGE MOUNTING STYLE

Setting Rotation Direction

- When inserting plunger into base, align desired letter to arrow head stamped on side of cylinder body.
 R=right swing rotation
 L=left swing rotation
 S=straight (no rotation)
- Insert plunger with proper tools. You may have to turn the plunger as you insert it to properly align ball in groove.

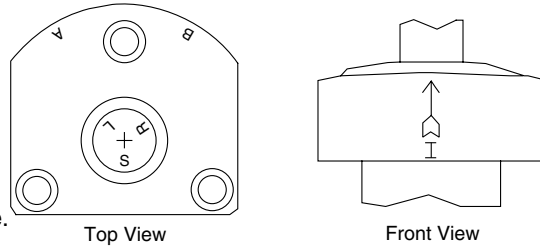

Single-Acting Models

- Lubricate all seals with Lubriplate prior to assembly.
- Lubricate ball and washer (items 18 & 19) with Lubriplate.
- Torque stop ring (item 2) to 8-15 ft-lbs (11-20 Nm).

Double-Acting Models

- Lubricate all seals with Lubriplate prior to assembly.
- Torque stop ring (item 2) to 8-15 ft-lbs (11-20 Nm).

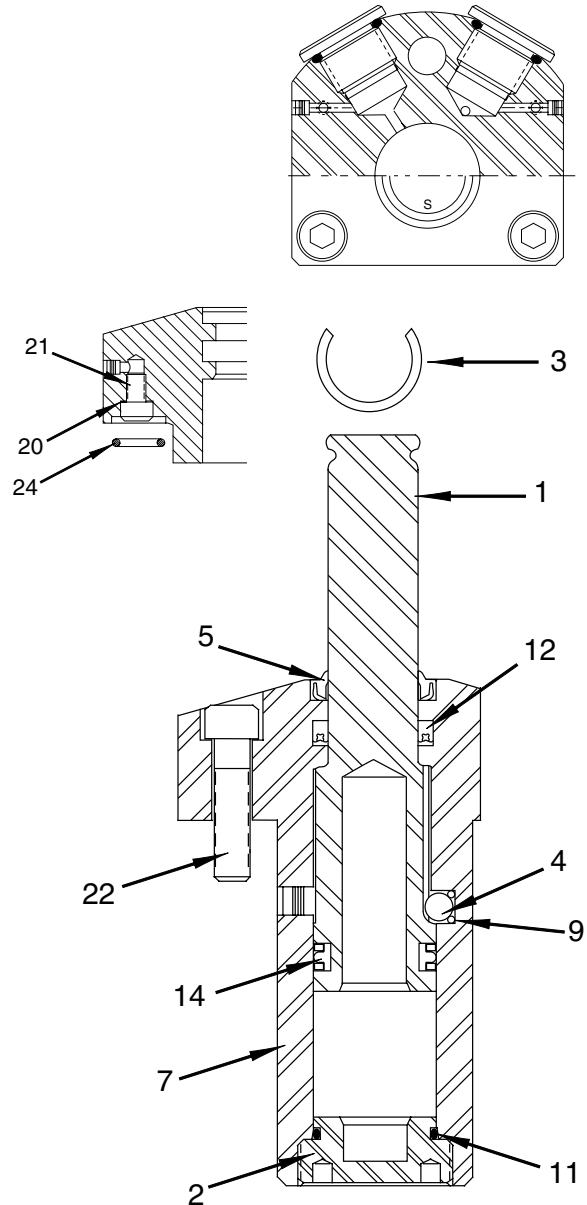
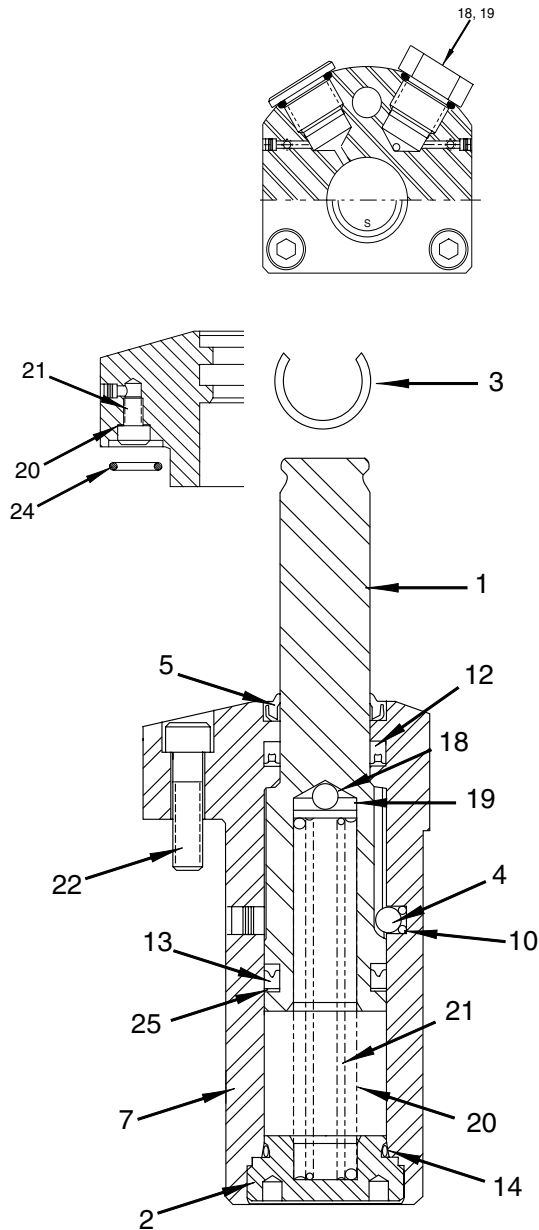

REPAIR PARTS LIST FOR 12 KN SWING CYLINDERS

Item No.	Standard Part Number	Viton Part Number	Quantity	Description
1	PA1065040	PA1065040	1	Plunger
2	PA1066044	PA1066044	1	Stop Ring
3	★ PA1112049	* PA112049	1	Retaining Ring
4	★ B1007016	* B1007016	1	Ball
5	★ DA12146776	* DA12146776	1	Wiper
6	not serviceable	not serviceable	1	Base--Threaded Body
7	not serviceable	not serviceable	1	Base--Upper Flange
8	not serviceable	not serviceable	1	Base--Lower Flange
9	★ B1006803	* B1006203	1	O-Ring (double-acting)
10	★ B1001503	* B1006203	1	O-Ring (single-acting)
11	★ B1025803	* B1025203	1	O-Ring
12	★ PA1105041	* PA1105041	1	U-Cup
13	★ PA1104041	* PA1104041	1	U-Cup--Single-Acting
14	★ B1214513	* B1214515	1	GT-Ring--Double-Acting
15	PA1103950SR	PA1103950SR	1	Vent Plug--Single-Acting
16	★ PA1109110	* PA1109110	1	Spring--Single-Acting
17	★ PA1108110	* PA1108110	1	Spring--Single-Acting
18	★ B1007016	* B1007016	1	Ball--Single-Acting
19	★ PA1107108	* PA1107108	1	Washer--Single-Acting
20	★ PA1303167	* PA1303167	2	Gasket
21	CCA411028-1A	CCA411028-1A	2	Bolt
22	B1352028	B1352028	3	Bolt--Upper Flange
23	B1354028	B1354028	3	Bolt--Lower Flange
24	★ B1011803	* B1011203	2	O-Ring
25	★ B1214564	* B1214564	1	Washer

★Items included in and available only as part of Repair Kit SS121K (Single-Acting) or SD121K (Double-Acting).
 *Items included in and available only as part of Repair Kit SS121KV (Single-Acting) or SD121KV (Double-Acting).

Australia

ENERPAC
Applied Power Australia, Ltd.
P.O. Box 261 Regents Park
Sydney, N.S.W. 2143
Tel: (61) (2) 9743 8988
Fax: (61) (2) 9743 8648

CIS

Applied Power Moscow
Leninsky Prospekt 95A
117313 Moscow, Russia
Tel: (7)(95) 936 5090
Fax: (7)(95) 936 2006

France, Switzerland, Turkey, Greece, Africa, Middle East

ENERPAC S.A.
Parc d'Activité du Moulin
de Massy
1 rue du Saule trapu, BP200
F-91882 Massy CEDEX
(Paris) France
Tel: (33) 1 60 13 68 68
Fax: (33) 1 69 20 37 50

Germany, Scandinavia, Eastern Europe, Austria, Switzerland

ENERPAC
Applied Power GmbH
P.O. Box 30 01 13
Mündelheimer Weg 51
40401 Düsseldorf 30
Germany
Tel: (49) (211) 47 14 90
Fax: (49) (211) 4714 928/940

Holland, Belgium, and Luxemburg

ENERPAC B.V.
P.O. Box 269, Storkstraat 25
3900AG Veenendaal
Holland
Tel: (31) (318) 535911
Fax: (31) (318) 525613/526645

Hong Kong

ENERPAC
Room No. 907, Workingberg
Commercial Building
41-47 Marble Road, North Point
Tel: (852) 561-6295
Fax: (852) 561-6772

India

ENERPAC
Hydraulics (India) Pvt Ltd.
203 Vardhaman Chamber
Plot #84, Sector 17
Vashi, New Bombay 400 705
India
Tel: 91-22-7631062
Fax: 91-22-7670309

Italy

ENERPAC
Applied Power Italiana S.p.A.
Via Canova, 4
20094 Corsico (Milano)
Italy
Tel: 39 2 45 82 741/2/3
Fax: 39 2 48 60 12 88

Japan

Applied Power Japan LTD
10-17 Sasame Kita-cho
Toda-City
Saitama 335,
Japan
Tel: 81 048 422 2251
Telex: J26275
Fax: 81 048 422 0596

Mexico

ENERPAC
Applied Power Mexico S.A. de C.V.
Av. Principal La Paz #100
Fracc. Industrial La Paz
42084 Pachuca. Hidalgo, Mexico
Tel: (52) 771 33700
Fax: (52) 771 83800

Singapore

Applied Power Asia Pte Ltd.
47 Jalan Pemimpin #01-02
Singapore 2057
01-03 Sin Cheong Building
Singapore 9157
Tel: (65) 258 1677
Fax: (65) 258 2847

South Korea

ENERPAC
Applied Power Korea Ltd.
163-12, Dodang-Dong
Wonmi-gu, Buchun-Shi,
Kyunggi-Do
Korea
Tel: (82) (32) 675 0836
Fax: (82) (32) 675 3002

Spain, Portugal

ENERPAC
Applied Power International, S.A.
Calle de la Imprenta, 7
Polígono Industrial
28100 Alcobendas (Madrid)
Spain
Tel: (34) 1 661 11 25
Fax: (34) 1 661 47 89

United Kingdom, Ireland

ENERPAC Ltd. Unit 3
Colemeadow Road
North Moons Moat
Redditch, Worcester B98 9BP
England
Tel: 44 01527 598 900
Fax: 44 01527 585 500

United States, Canada, Latin America and Caribbean

ENERPAC
13000 West Silver Spring Drive
Butler, Wisconsin 53007, USA
Tel: (414) 781-6600
1-800-433-2766 (End User)
1-800-558-0530 (Distributor)
Fax: (414) 781-1049

Canada

Tel: 1-800-426-4129 (End User)
Tel: 1-800-426-2284 (Distributor)

Latin America and Caribbean

Tel: (414) 781-6600 ext. 263
Fax: (414) 781-5561



All Enerpac products are guaranteed against defects in workmanship and materials for as long as you own them. Under this guarantee, free repair or replacement will be made to your satisfaction.

For prompt service, contact your Authorized Enerpac Service Center or call toll free:

**In U.S.A. 1-800-558-0530
In Canada 1-800-426-2284**

PRINTED IN U.S.A.