

**Index:**

English.....	1-2
Português.....	3-4
Polski.....	5-6

Repair Parts Sheet	Revision	Revision Date	Product Code Beginning
L1217	Q	09/20	A: RCS 101/201 B: RCS 302 D: RCS 502/1002

▲ = Parts available in kits (see page 2).

\* See  on page 2.

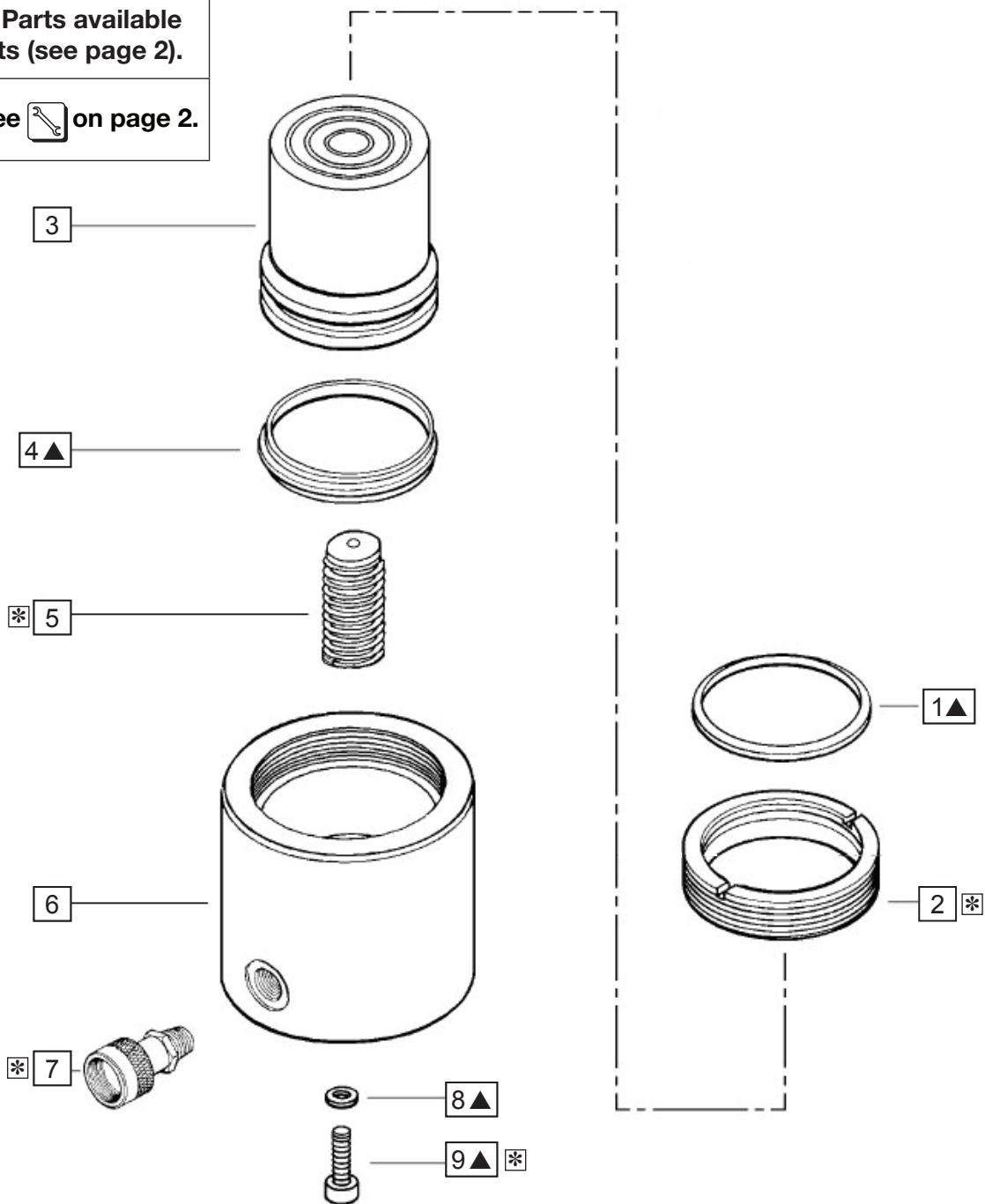

## Repair Parts List

Item nr.	Description	Qty.	RCS101	RCS201	RCS302	RCS502	RCS1002	
1	Wiper Ring	1	▲	▲	▲	▲	▲	
2	Stop Ring	1	CR28044	CR39044	CR83044	DA2556044	CR106044	
3	Plunger	1	CR80040	CR79040	CR78040	DA2557040	DA9419040	
4	G-T Ring	1	▲	▲	▲	▲	▲	
5	Spring assy.	1	CU678900	CU678900	DC5215900	DC5215900	DC5215900	
6	Cylinder Base	1	Not available as a service item. Order a new cylinder.					
7	Coupler	1	CR400	CR400	CR400	CR400	CR400	
8	Gasket	1	▲	▲	▲	▲	▲	
9	Screw	1	▲	▲	▲	▲	▲	
10	Caution decal (not shown)	1	▲	▲	▲	▲	▲	
11	Enerpac decal (not shown)	1	▲	▲	▲	▲	▲	
12	Dust Cap (not shown)	1	▲	▲	▲	▲	▲	
13	Handle	1	-	-	-	-	CM584070	
▲	Repair Kit		RCS101K	RCS201K	RCS302K	RCS502K	RCS1002K	

▲ = Indicates item included as part of repair kit (not sold separately).  
Parts included in repair kits will vary, depending on kit ordered.



Service Notes		
Item	Model	Torque / Remark
2	All	Apply Loctite 222 to threads
5	RCS101 / 201	40 – 45 in-lbs [4.5 – 5.1 Nm]
5	RCS302 / 502 / 1002	90 – 95 in-lbs [10.2 – 10.7 Nm]
7	All	25 – 60 ft-lbs [34 – 81 Nm]
7	All	Use Loctite 545 or Teflon tape
9	RCS101 / 201	40 – 45 in-lbs [4.5 – 5.1 Nm]
9	RCS302 / 502 / 1002	90 – 95 in-lbs [10.2 – 10.7 Nm]
13	RCS1002	Secure with Loctite 242

Folha de peças sobressalentes	Revisão	Data de revisão	Prefixo código do produto
L1217	Q	09/2020	R: RCS 101/201 B: RCS 302 D: RCS 502/1002

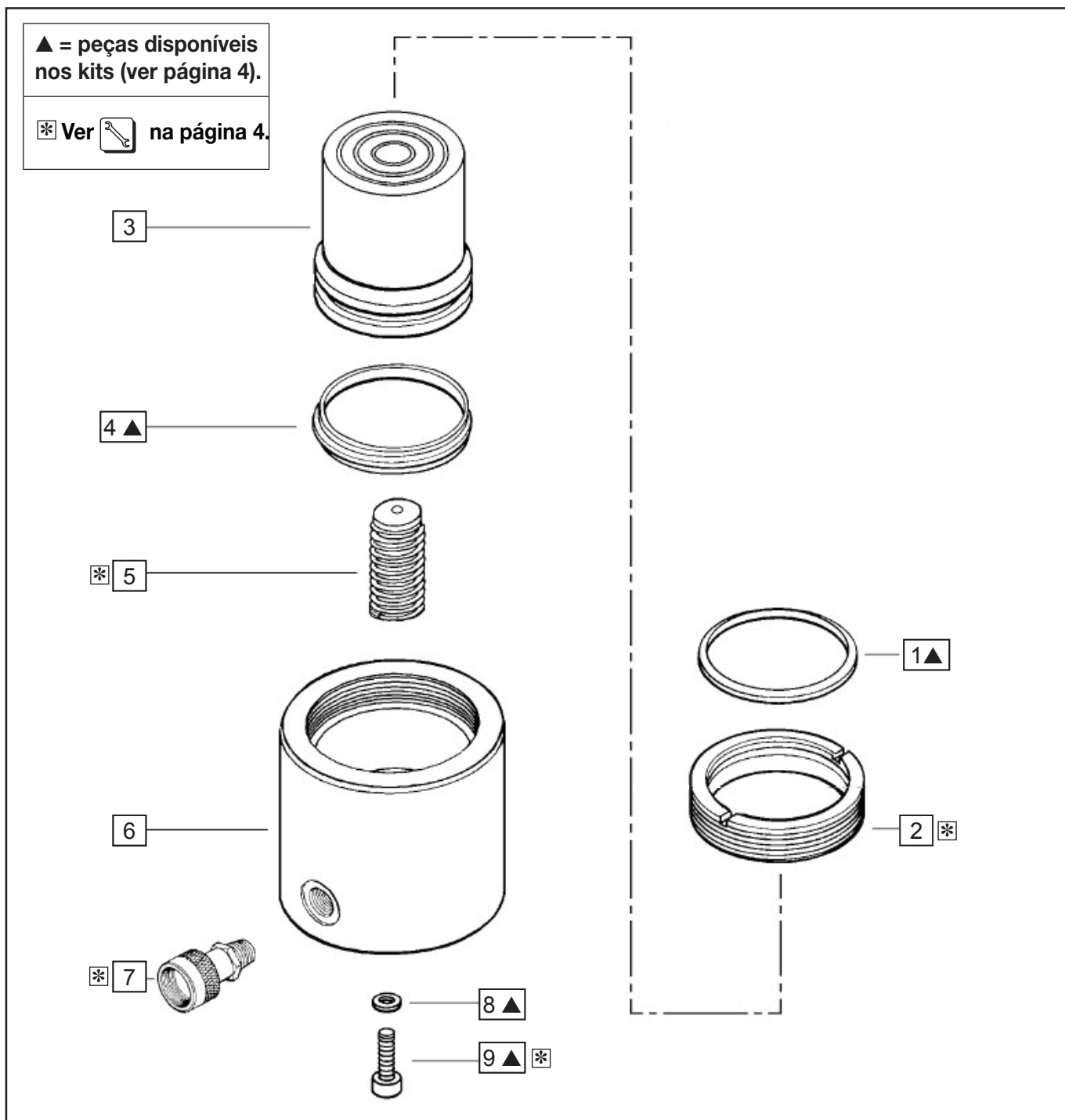

# Lista de peças sobressalentes

# L1217

N.º do item	Descrição	Qtd.	RCS101	RCS201	RCS302	RCS502	RCS1002	
1	Anel do raspador	1	▲	▲	▲	▲	▲	
2	Anel de limite	1	CR28044	CR39044	CR83044	DA2556044	CR106044	
3	Êmbolo	1	CR80040	CR79040	CR78040	DA2557040	DA9419040	
4	Anel G-T	1	▲	▲	▲	▲	▲	
5	Conjunto de molas	1	CU678900	CU678900	DC5215900	DC5215900	DC5215900	
6	Base do cilindro	1	Não disponível como item de serviço. Encomende um cilindro novo.					
7	Acoplador	1	CR400	CR400	CR400	CR400	CR400	
8	Junta	1	▲	▲	▲	▲	▲	
9	Parafuso	1	▲	▲	▲	▲	▲	
10	Autocolante Cuidado (não ilustrado)	1	▲	▲	▲	▲	▲	
11	Autocolante Enerpac (não ilustrado)	1	▲	▲	▲	▲	▲	
12	Tampa (não ilustrado)	1	▲	▲	▲	▲	▲	
13	Cabo	1	-	-	-	-	CM584070	
▲	Kit de reparação		RCS101K	RCS201K	RCS302K	RCS502K	RCS1002K	

▲ = indica itens incluídos no kit de reparação (não em separado).

As peças incluídas nos kits de reparação variam de acordo com o kit encomendado.



## Notas de serviço

Item	Modelo	Torque/observação
2	Todos	Aplicar Loctite 222 nas roscas
5	RCS101 / 201	40 – 45 in-lbs [4,5 – 5,1 Nm]
5	RCS302 / 502 / 1002	90 – 95 in-lbs [10,2 – 10,7 Nm]
7	Todos	25 – 60 ft-lbs [34 – 81 Nm]
7	Todos	Usar Loctite 545 ou fita de teflon
9	RCS101 / 201	40 – 45 in-lbs [4,5 – 5,1 Nm]
9	RCS302 / 502 / 1002	90 – 95 in-lbs [10,2 – 10,7 Nm]
13	RCS1002	Prenda com Loctite 242

# ENERPAC

Consulte o site [www.enerpac.com](http://www.enerpac.com) para encontrar o Centro de Assistência Autorizado da Enerpac mais próximo.

Karta części zamiennych	Wersja	Data wprowadzenia zmian	Początek kodu produktu
L1217	Q	09/2020	A: RCS 101/201 B: RCS 302 D: RCS 502/1002

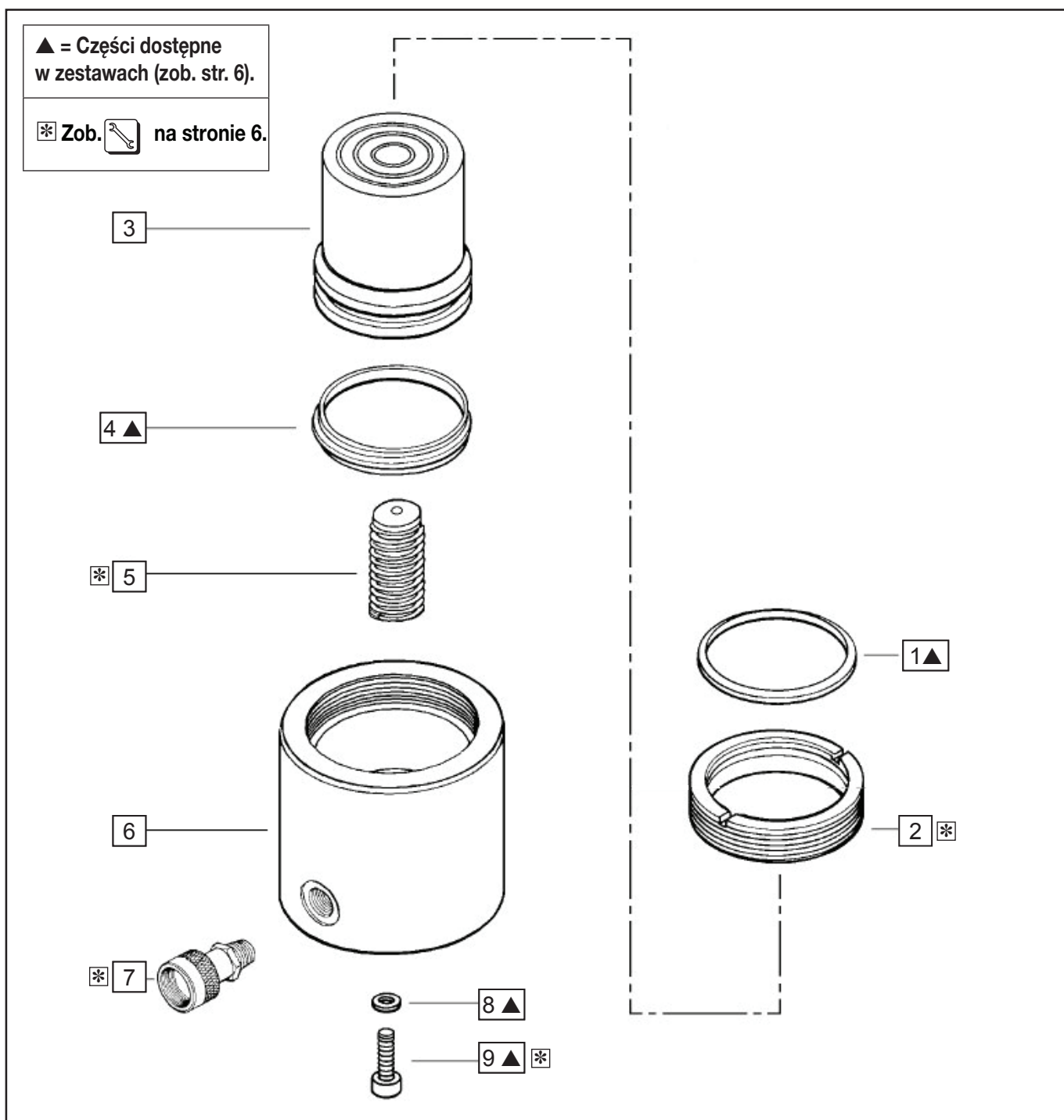

## Lista części zamiennych

Część nr	Opis	Ilość	RCS101	RCS201	RCS302	RCS502	RCS1002	
1	Uszczelka zgarniająca	1	▲	▲	▲	▲	▲	
2	Ogranicznik	1	CR28044	CR39044	CR83044	DA2556044	CR106044	
3	Tłok	1	CR80040	CR79040	CR78040	DA2557040	DA9419040	
4	Uszczelka G-T	1	▲	▲	▲	▲	▲	
5	Zespół sprężyny	1	CU678900	CU678900	DC5215900	DC5215900	DC5215900	
6	Podstawa cylindra	1	Niedostępna jako część zamienna. Zamów nowy cylinder.					
7	Złączka	1	CR400	CR400	CR400	CR400	CR400	
8	Uszczelka	1	▲	▲	▲	▲	▲	
9	Śruba	1	▲	▲	▲	▲	▲	
10	Oznaczenia ostrzegawcze (brak na rysunku)	1	▲	▲	▲	▲	▲	
11	Nalepki Enerpac (brak na rysunku)	1	▲	▲	▲	▲	▲	
12	Pokrywa przeciwpyłowa (brak na rysunku)	1	▲	▲	▲	▲	▲	
13	Rękojeść	1	-	-	-	-	CM584070	
▲	Zestaw naprawczy		RCS101K	RCS201K	RCS302K	RCS502K	RCS1002K	

▲ = Oznacza część dołączoną do zestawu naprawczego (nie są sprzedawane osobno).

Części znajdujące się w zestawach naprawczych będą się różnić w zależności od zamówionego zestawu.



### Uwagi dotyczące serwisowania

Część	Model	Moment obrotowy / Uwaga
2	Wszystkie	Nałożyć Loctite 222 na gwinty
5	RCS101 / 201	40 – 45 in-lbs [4,5 – 5,1 Nm]
5	RCS302 / 502 / 1002	90 – 95 in-lbs [10,2 – 10,7 Nm]
7	Wszystkie	25 – 60 in-lbs [34 – 81 Nm]
7	Wszystkie	Nałożyć Loctite 545 lub taśmę teflonową
9	RCS101 / 201	40 – 45 in-lbs [4,5 – 5,1 Nm]
9	RCS302 / 502 / 1002	90 – 95 in-lbs [10,2 – 10,7 Nm]
13	RCS1002	Zabezpieczony z Loctite 242

**ENERPAC**

Na stronie [www.enerpac.com](http://www.enerpac.com) znajdziesz adres najbliższego autoryzowanego centrum serwisowego firmy Enerpac.





[www.enerpac.com](http://www.enerpac.com)