

L2792 Rev. B 08/11

For Date Codes Beginning with the Letter "A", "B" or "C"

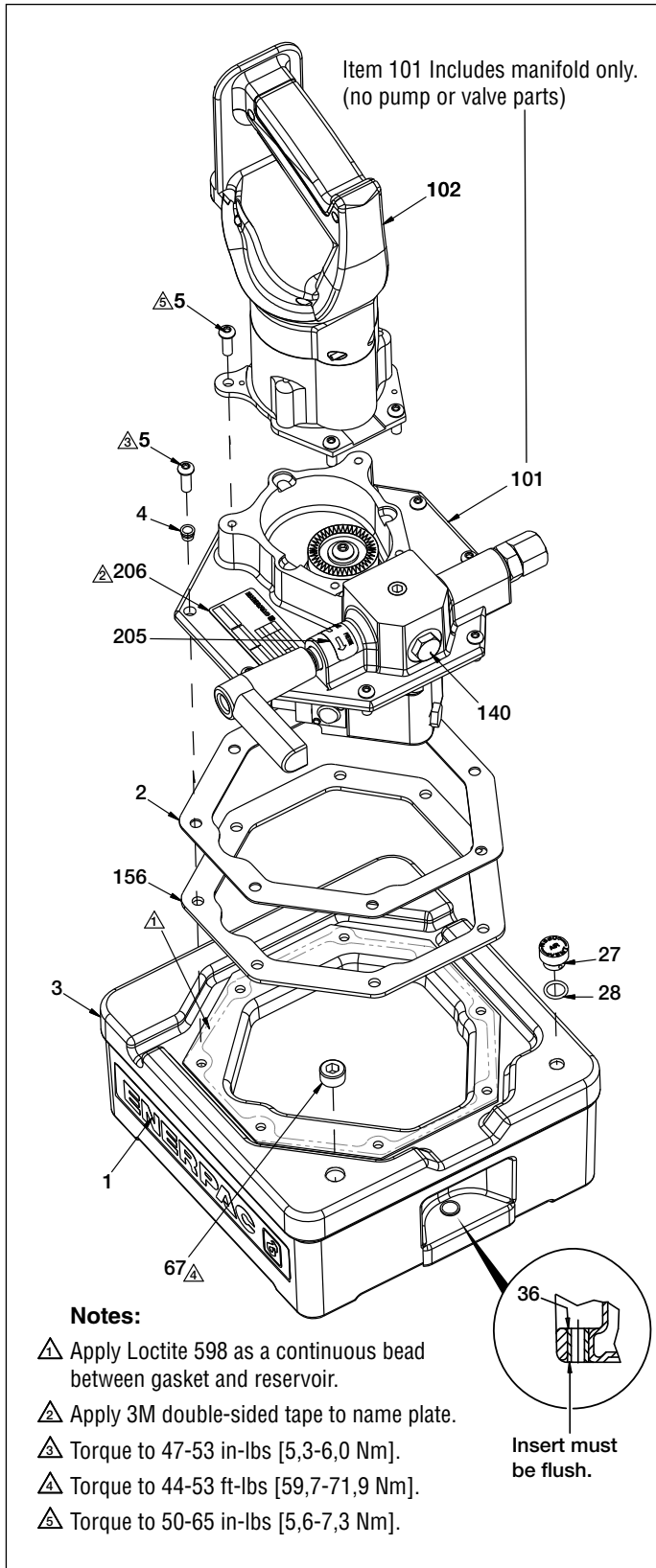

Figure 1, Main Assembly

Repair Parts List for Figure 1

Item	Part Number	Qty.	Description
1	◆ DD1042026	2	Decal, Reservoir
2	★◆ DA12088167	1	Gasket
3	DA1910900SR	1	Reservoir Assembly Kit, 2L
	DA4780900SR	1	Reservoir Assembly Kit, 4L
4	◆ DA6954167	8	Gasket
5	DC2038028	12	Capscrew, Button Head
27	DA608024	1	Vent Plug
28	★ B1906503	1	O-Ring
36	◆ DA931225	2	Insert
67	◆ A1009245	1	Plug, 3/8 Flush
101	DD1047840	1	Pump Manifold
102	DD1079960SR	1	Subassembly, Powerhead
140	R515245-2	1	Plug
156	★◆ DA12089167	1	Gasket
205	DD1083026	1	Decal, Pressure/Release
206	DD1084026	1	Nameplate

◆ Included with Reservoir Assembly Kits DA1910900SR and DA4780900SR (see item 3). ★ Included in Repair Kit BP1K1.

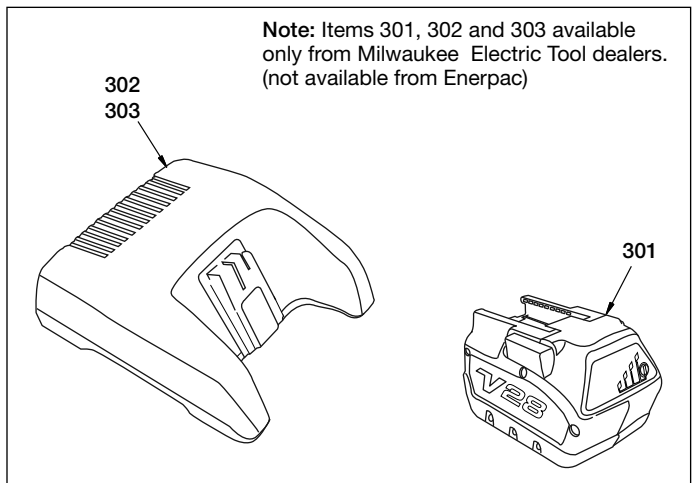

Figure 2, Battery and Charger

Repair Parts List for Figure 2

Item	Milwaukee Electric Tool Part Number	Qty.	Description
301	48-11-2830	1	Battery, 28 Volt Li-Ion
302	48-59-2818	1	Battery Charger, 115 VAC input
303	48-59-2810	1	Battery Charger, 230 VAC input

Note: "V28™", "VTM-technology" and the Milwaukee Electric Tool logo are trademarks and intellectual property of Milwaukee Electric Tool Corporation.

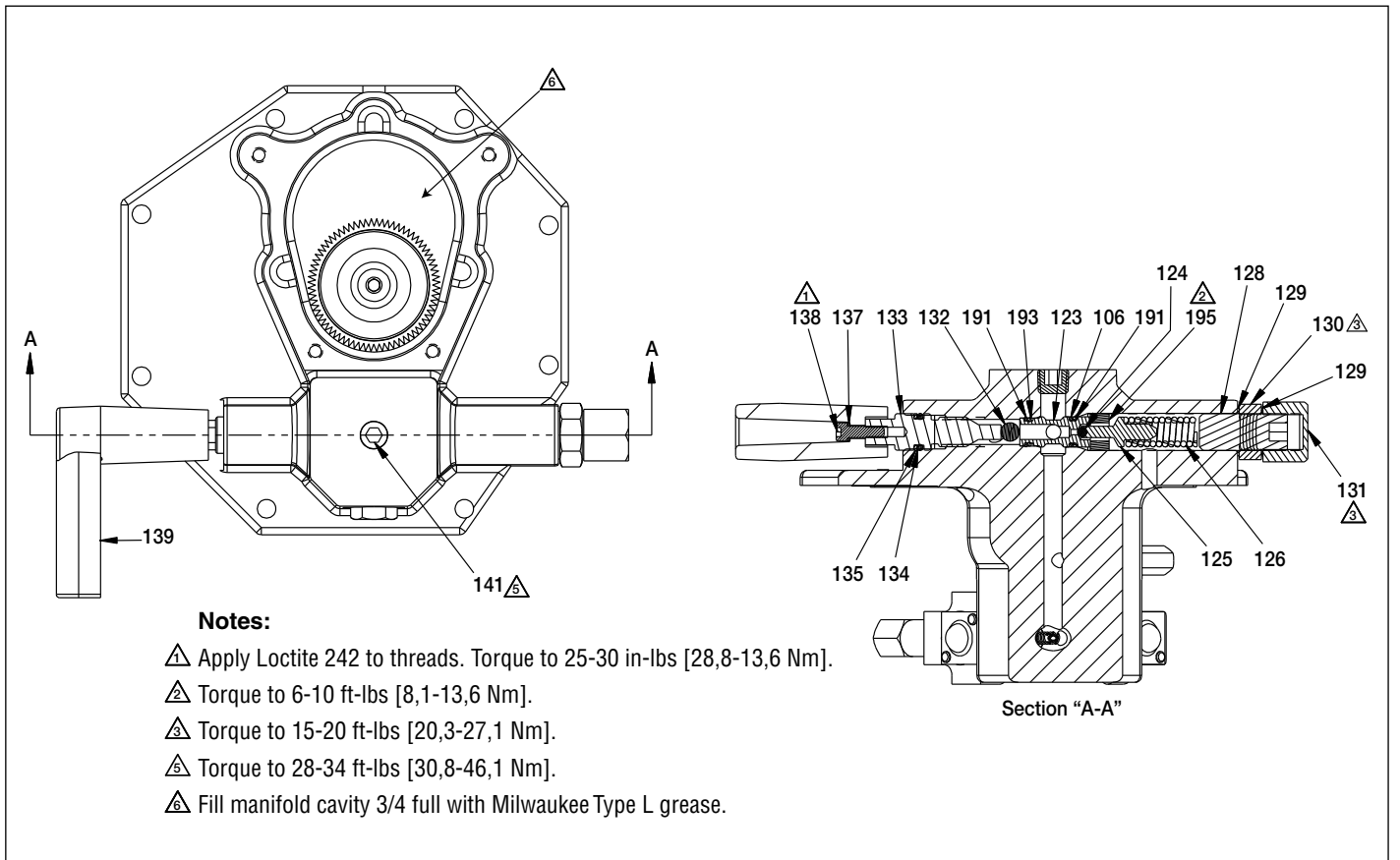

Figure 3, Valve And Mainfold Assy

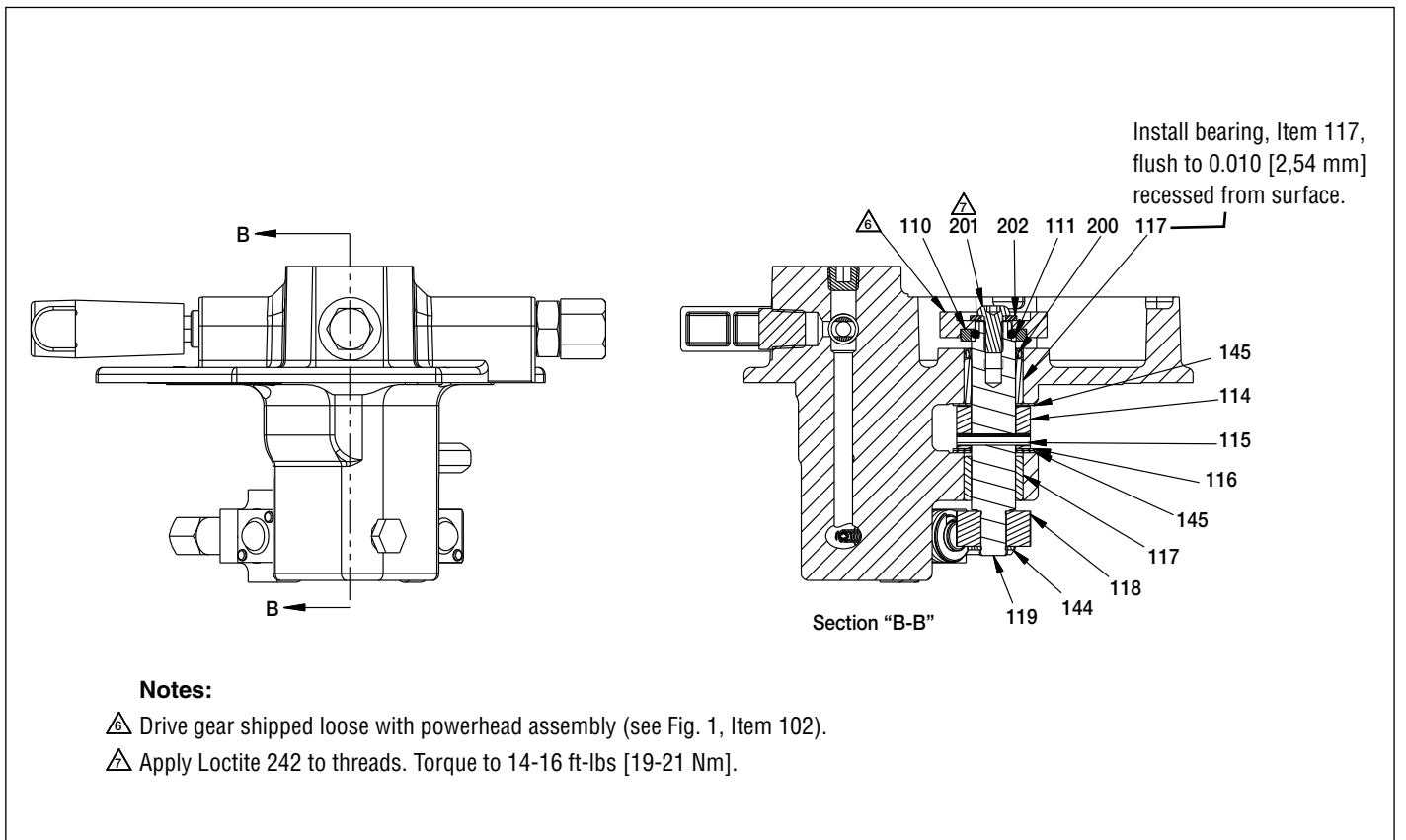

Figure 4, Pump Shaft Details

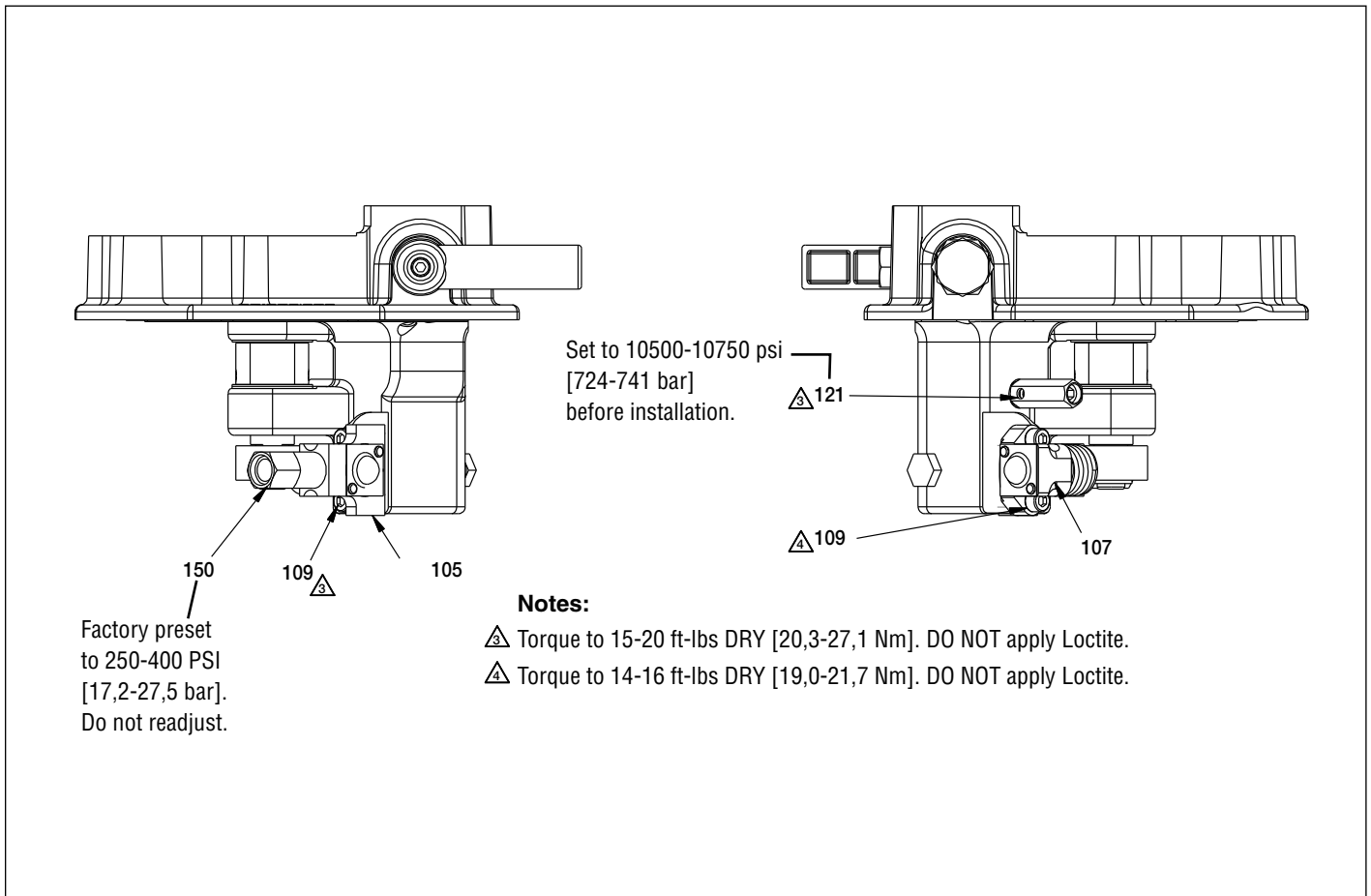

Figure 5, Piston Block Assemblies

Repair Parts List for Figures 3, 4 and 5

Item	Part Number	Qty.	Description	Item	Part Number	Qty.	Description
105	❖ CW298950SR	1	Piston Block Assy (0.53 inch)	129	★ S1167	2	Gasket
	❖ DD1449051SR	1	Piston Block Assy (14.0 mm)	130	CW306055	1	Lock Nut
106	★ B1007503	1	O-Ring	131	CW307055	1	Cap Nut
107	❖ CW299950SR	1	Piston Block Assy (0.24 inch)	132	★ B1009016	1	Ball (0.312 in. dia.)
	❖ DD1450051SR	1	Piston Block Assy (6.0 mm)	133	C790010SR	1	Stem
109	B1016028	4	Screw	134	★ B1111203	1	O-Ring, Viton
110	DD1035038	1	Motor Gear Adapter	135	★ B1111564	1	Washer
111	★ DD1036015	4	Ball (9/64 in. dia)	137	B1086066	1	Lockwasher
114	DD1034186	1	Spacer, Eccentric	138	B1324028	1	Screw, Socket Head
115	★ B1097057	1	Spring Pin	139	DA544070	1	Handle
116	★ CW199107	1	Bearing	141	A1008245	1	Plug
117	CW251107	2	Bearing	144	★ CW467044	1	Retaining Ring
118	CW302107	1	Bearing	145	★ DA445107	2	Bearing
119	DD1033104	1	Eccentric Shaft	150	DA610900SR	1	Relief Valve Assembly
121	DA11535900	1	Relief Valve (internal)	191	★ B1012565	2	Washer, Back-up
123	★ DA12199290	1	Ball Seat Insert	193	★ DC19503	1	O-Ring
124	★ B1004016	1	Ball (0.156 in. dia.)	195	DC866027	1	Lock Screw
125	DC990900SR	1	Ball Guide Assy (includes #124)	200	★ DD1037476	1	Oil Seal
126	★ A109164	1	Compression Spring	201	CBA819028-1E	1	Screw, M8 x 1.25
128	DA252028	1	Adjusting Screw	202	CAE1100108-1A	1	Washer, Zinc 10mm

❖ Used only on pumps with date codes "A" and "B". ❖ Used only on pumps with date code "C". ★ Included in Repair Kit BP1K1

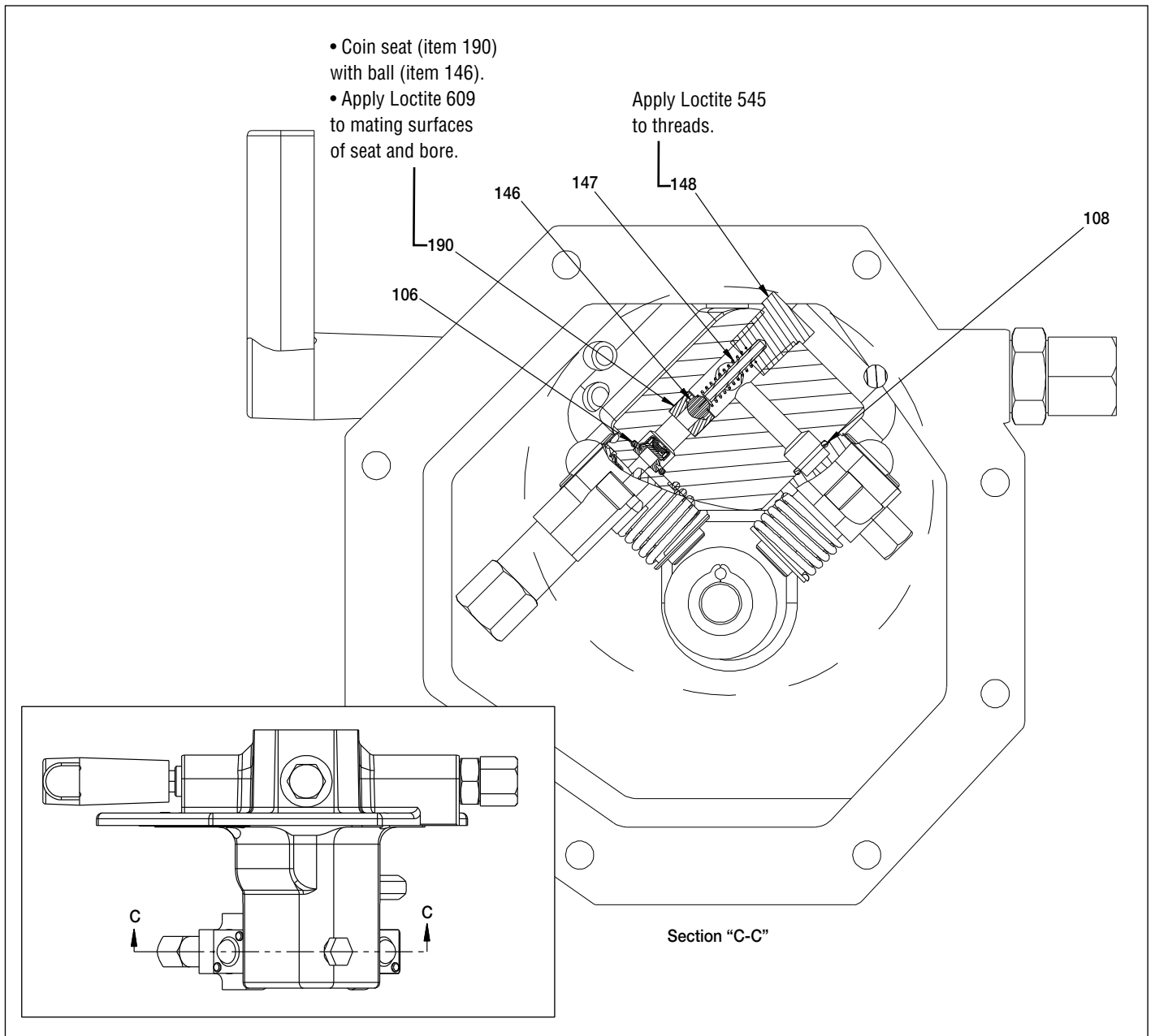

Figure 6, Pump Check Ball Assembly (bottom view)

Repair Parts List for Figure 6							
Item	Part Number	Qty.	Description	Item	Part Number	Qty.	Description
106	★B1007503	1	O-Ring	147	★DA1564110	1	Spring
108	★B1012803	1	O-Ring	148	DC433950	1	Plug Assembly
146	★B1007016	1	Ball (0.25 in dia.)	190	DA12352290	1	Ball Seat

★ Included in Repair Kit BP1K1.

Enerpac Worldwide Locations

◆ e-mail: info@enerpac.com

◆ internet: www.enerpac.com

Australia and New Zealand

Actuant Australia Ltd.
Block V Unit 3
Regents Park Estate
391 Park Road
Regents Park NSW 2143
(P.O. Box 261) Australia
T +61 (0)2 9743 8988
F +61 (0)2 9743 8648
sales-au@enerpac.com

Brazil

Power Packer do Brasil Ltda.
Rua dos Inocentes, 587
04764-050 - Sao Paulo (SP)
T +55 11 5687 2211
F +55 11 5686 5583
Toll Free: 0800 891 5770
ventasbrasil@enerpac.com

Canada

Actuant Canada Corporation
6615 Ordan Drive, Unit 14-15
Mississauga, Ontario L5T 1X2
T +1 905 564 5749
F +1 905 564 0305
Toll Free:
T +1 800 268 4987
F +1 800 461 2456
customer.service@actuant.com

China

Actuant (China) Industries Co. Ltd.
No.6 Nanjing East Road,
Taicang Economic Dep Zone
Jiangsu, China
T +86 0512 5328 7500
F +86 0512 5335 9690
Toll Free: +86 400 885 0369
sales-cn@enerpac.com

France, Switzerland, North Africa and French speaking African countries

ENERPAC
Une division d'ACTUANT France S.A.S.
ZA de Courtaboeuf
32, avenue de la Baltique
91140 VILLEBON /YVETTE
France
T +33 1 60 13 68 68
F +33 1 69 20 37 50
sales-fr@enerpac.com

Germany and Austria

ENERPAC GmbH
P.O. Box 300113
D-40401 Düsseldorf
Willstätterstrasse 13
D-40549 Düsseldorf, Germany
T +49 211 471 490
F +49 211 471 49 28
sales-de@enerpac.com

India

ENERPAC Hydraulics Pvt. Ltd.
No. 1A, Peenya Industrial Area
IInd Phase, Bangalore, 560 058, India
T +91 80 40 792 777
F +91 80 40 792 792
sales-in@enerpac.com

Italy

ENERPAC S.p.A.
Via Canova 4
20094 Corsico (Milano)
T +39 02 4861 111
F +39 02 4860 1288
sales-it@enerpac.com

Japan

Applied Power Japan LTD KK
Besshocho 85-7
Kita-ku, Saitama-shi 331-0821, Japan
T +81 48 662 4911
F +81 48 662 4955
sales-jp@enerpac.com

Middle East, Egypt and Libya

ENERPAC Middle East FZE
Office 423, LOB 15
P.O. Box 18004, Jebel Ali, Dubai
United Arab Emirates
T +971 (0)4 8872686
F +971 (0)4 8872687
sales-ua@enerpac.com

Russia

Rep. office Enerpac
Russian Federation
Admirala Makarova Street 8
125212 Moscow, Russia
T +7 495 98090 91
F +7 495 98090 92
sales-ru@enerpac.com

Singapore

Actuant Asia Pte Ltd.
83 Joo Koon Circle
Singapore 629109
T +65 68 63 0611
F +65 64 84 5669
Toll Free: +1800 363 7722
sales-sg@enerpac.com

South Korea

Actuant Korea Ltd.
3Ba 717, Shihwa Industrial Complex
Jungwang-Dong, Shihung-Shi,
Kyunggi-Do
Republic of Korea 429-450
T +82 31 434 4506
F +82 31 434 4507
sales-kr@enerpac.com

Spain and Portugal

ENERPAC SPAIN, S.L.
Avda. Los Frailes, 40 – Nave C & D
Pol. Ind. Los Frailes
28814 Daganzo de Arriba
(Madrid) Spain
T +34 91 884 86 06
F +34 91 884 86 11
sales-es@enerpac.com

Sweden, Denmark, Norway, Finland and Iceland

Enerpac Scandinavia AB
Fabriksgatan 7
412 50 Gothenburg
Sweden
T +46 (0) 31 799 0281
F +46 (0) 31 799 0010
scandinavianinquiries@enerpac.com

The Netherlands, Belgium, Luxembourg, Central and Eastern Europe, Baltic States, Greece, Turkey and CIS countries

ENERPAC B.V.
Galvanistraat 115
6716 AE Ede
P.O. Box 8097
6710 AB Ede
The Netherlands
T +31 318 535 800
F +31 318 535 848
sales-nl@enerpac.com

Enerpac Integrated Solutions B.V.

Opaalstraat 44
7554 TS Hengelo
P.O. Box 421
7550 AK Hengelo
The Netherlands
T +31 74 242 20 45
F +31 74 243 03 38
integratedsolutions@enerpac.com

South Africa and other English speaking African countries

ENERPAC B.V.
Galvanistraat 115
6716 AE Ede
P.O. Box 8097
6710 AB Ede
The Netherlands
T +31 318 535 911
F +31 318 525 613
sales-za@enerpac.com

United Kingdom and Ireland

ENERPAC Ltd.,
Bentley Road South
Darlaston, West Midlands
WS10 8LQ
England
T +44 (0)121 50 50 787
F +44 (0)121 50 50 799
sales-uk@enerpac.com

USA, Latin America and Caribbean

ENERPAC
P.O. Box 3241
Milwaukee WI 53201 USA
T +1 262 293 1600
F +1 262 293 7036
User inquiries:
T +1 800 433 2766
Distributor inquiries/orders:
T +1 800 558 0530
F +1 800 628 0490
Technical inquiries:
techservices@enerpac.com
sales-us@enerpac.com

All Enerpac products are guaranteed
against defects in workmanship and
materials for as long as you own them.

For the location of your nearest authorized
Enerpac Service Center, visit us at
www.enerpac.com

071411

Note: Rechargeable Li-Ion battery packs are guaranteed for 1000 charges or 2 years, whichever comes first.
Consult your Enerpac Authorized Service Center for additional battery warranty information.